

Pagination

* BL

Majority Opinion >

UNITED STATES DISTRICT COURT FOR THE SOUTHERN DISTRICT OF NEW YORK

THERABODY, INC., Plaintiff, - against - TZUMI ELECTRONICS LLC, et al., Defendants.

21-CV-7803 (PGG) (RWL)

November 28, 2022, Filed

November 28, 2022, Decided

For Therabody Inc., a Delaware corporation, Plaintiff: Cameron Westin, O'Melveny & Myers LLP, Newport Beach, CA; Diane Christine Ragosa, Parker Ibrahim & Berg LLC, Somerest, NJ; Laura Bayne Gore, O'Melveny & Myers LLP(NYC), New York, NY; Thomas McClinton Harris, O'Melveny & Myers LLP, Newport Beach, CA; Brett Johnston Williamson, LEAD ATTORNEY, O'Melveny & Myers LLP(NYC), New York, NY; Marc Joseph Pensabene, LEAD ATTORNEY, O'Melveny & Myers LLP, New York, NY.

For Tzumi Electronics LLC, a New York company, Tzumi Inc., a New York Corporation, Defendants: Katherine Marguerite Lieb, Sills Cummis & Gross P.C., New York, NY.

For Tzumi Electronics LLC, a New York Company, Tzumi Inc., a New York corporation, Defendants: Scott David Stimpson, Sills Cummis & Gross P.C., New York, NY.

For Tzumi Electronics LLC, a New York Company, Tzumi Inc., a New York Corporation, Defendants: Steven Ze'Ev Luksenberg, Phillips Nizer LLP, New York, NY.

For Tzumi Electronics LLC, a New York Company, Defendant: Scott David Stimpson, LEAD ATTORNEY, Sills Cummis & Gross P.C., New York, NY.

ROBERT W. LEHRBURGER, UNITED STATES MAGISTRATE JUDGE.

ROBERT W. LEHRBURGER

REPORT AND RECOMMENDATION TO HON. PAUL G. GARDEPHE: DEFENDANT'S MOTION FOR PARTIAL SUMMARY JUDGMENT

ROBERT W. LEHRBURGER, United States Magistrate Judge.

Plaintiff Therabody, Inc. ("Therabody") alleges that Defendants Tzumi Electronics LLC, Tzumi Inc., and Does 1-10 ("Tzumi" or "Defendants") infringe fourteen utility and design patents directed to three-handled percussive massage devices and their attachments. Tzumi now moves for partial summary judgment of noninfringement of four of the utility patents under Federal Rule of Civil Procedure 56 ("Rule 56 "). For the reasons that follow, I recommend that Tzumi's motion be DENIED.

PROCEDURAL HISTORY

Therabody commenced this action on September 17, 2021. (Dkt. 1.) The operative complaint is the Second Amended Complaint ("SAC"), filed on May 9, 2022. (Dkt. 53.)

From the start, the parties contemplated a case schedule providing a ten-month period for the parties to set forth their infringement, validity, and claim construction contentions and eventual briefing of the same. In their proposed case management plan and scheduling order filed on December 30, 2021, the parties proposed service of Therabody's disclosure of asserted claims and infringement contentions on January 27, 2022, followed by Defendants' validity contentions two to three months later, followed by claim construction charts and briefing from June 12, 2022 to October 10, 2022. (Dkt. 27 at 3-4.) On March 31, 2022, the parties filed a similar proposed schedule spanning April 27, 2022 through January 10, 2023. (Dkt. 41 at 3-4.) Finally, on May 4, 2022, the parties again submitted a similar proposed schedule spanning June 3, 2022 to March 3, 2023, and requiring filing of a Joint Disputed Claim Terms Chart by November 2, 2022; Plaintiff's opening claim construction brief by December 16, 2022; Defendant's responsive claim construction brief [*2] by February 3, 2023, and Plaintiff's reply by March 3, 2023. (Dkt. 50 at 3-4.) The Court so-ordered that schedule on May 5, 2022. (Dkt. 51.)

Despite the schedule structure jointly proposed by the parties and ultimately approved by the Court, Tzumi filed a letter on March 18, 2022 requesting a pre-motion conference to discuss its planned motion for summary judgment of noninfringement of two patents which it represented would account for the vast majority of accused sales, thereby facilitating settlement of Therabody's remaining claims. (Dkt. 38.) Therabody filed a letter in opposition challenging Tzumi's claim construction and infringement arguments, and contending the motion would be premature and unnecessary given the parties' agreement to a conventional claim construction process. (Dkt. 39.) After a conference, the Court set a briefing schedule to be followed "if Defendant proceeds with its intended motion for partial summary judgment." (Dkt. 49 ¶ 4.)

Tzumi opted to proceed, filing the instant motion on June 7, 2022. (Dkts. 67-69.) Therabody filed its opposition on August 5, 2022. (Dkts. 70-71.) The motion was fully briefed with Tzumi's reply on August 22, 2022. (Dkt. 72.) The Court heard oral argument on November 16, 2022.

FACTUAL BACKGROUND 1

Relevant to this motion, Therabody asserts infringement of the following claims: independent claims 1 and 6 of U.S. Patent No. 10 , 702 ,448 ("the '448 Patent," Ex. E); claims 1, 8, 9, 10, 14, 15, and 16 of U.S. Patent No. 10 , 918 ,565 ("the '556 Patent," Ex. F); independent claims 1 and 16 of U.S. Patent No. 10 , 857 ,064 ("the '064 Patent," Ex. G); and independent claims 1, 6, 11, and 17 of U.S. Patent No. 11 , 160 ,722 ("the '722 Patent," Ex. H).² (Pl. 56.1 Statement at 2.³) According to Tzumi, all of those claims contain "grasping limitations" which, under its proposed claim construction, require that "all three handles [of the percussive massage device] must be of a length sufficient for a person with a large hand to firmly and comfortably grip each handle portion with at least three to four fingers extending through the opening." (Def. 56.1 Statement ¶ 2;⁴ Def. Mem. at 1-2, 11.⁵) Tzumi asserts that because its accused devices — the "Accused Products" — cannot be so grasped, they cannot literally infringe the asserted claims. Tzumi also contends that Therabody's statements and amendments during prosecution of the patents estop it from asserting infringement under the doctrine of equivalents. (Def. Mem. at 2.)

For purposes of the instant motion, the Court treats claims 1 and 6 of the '448 Patent as representative of the asserted claims with "grasping limitations." Claims 1 and 6 read as follows, with the "grasping limitations" emphasized:

1. A method of using a percussive massage device, the method comprising the steps of:

obtaining the percussive massage device, wherein the percussive massage device includes a housing that includes first, second and third handle portions that cooperate to define a handle opening, an electrical source, a motor positioned in the housing, a switch for activating the motor, and a push rod assembly operatively connected to the motor and configured to reciprocate in response to activation of the motor, wherein the first handle portion defines a first axis, **[*3]** the second handle portion defines a second axis and the third handle portion defines a third axis, and wherein the first, second and third axes cooperate to form a triangle, wherein the first handle portion is generally straight, wherein the second handle portion is generally straight, and wherein the third handle portion is generally straight,

activating the motor using the switch,

grasping the first handle portion,

massaging a first body part,

grasping the second handle portion and massaging the first body part, and

grasping the third handle portion and massaging the first body part.

('448 Patent at 22:24-48.)

6. A percussive massage device comprising:

a housing, wherein the housing includes first, second and third handle portions that cooperate to

define a handle opening, wherein the first handle portion defines a first axis, the second handle portion defines a second axis and the third handle portion defines a third axis, wherein the first, second and third axes cooperate to form a triangle, wherein the first handle portion is generally straight, wherein the second handle portion is generally straight, and wherein the third handle portion is generally straight, **such that a user can grasp any of the first, second or third handle portions independently to use the percussive massage device,**

an electrical source,

a motor positioned in the housing,

a switch for activating the motor, and

a push rod assembly operatively connected to the motor and configured to reciprocate in response to activation of the motor.

('448 Patent at 23:24-42.)

The following sections summarize the relevant patents, their prosecution history, and the Accused Products.

1. The '448 Patent"

The '448 Patent claims a "percussive massage device and method of use." The patent issued on July 7, 2020.⁶ The application for the '448 Patent was filed on November 6, 2019 and assigned application number 16/675, 772. ('448 Patent at 1.)

As originally filed, claim 1 read in relevant part:

1. A method of using a percussive massage device, the method comprising the steps of:

obtaining the percussive massage device, wherein the percussive massage device includes a housing that includes first, second and third handle portions that cooperate to define a handle opening, an electrical source, a motor positioned in the housing, a switch for activating the motor, and a push rod assembly operatively connected to the motor and configured to reciprocate in response to activation of the motor,

activating the motor using the switch,

grasping the first handle portion,

massaging a first body part,

alternatively grasping the second handle portion and massaging the first body part, and

alternatively grasping the third handle portion and massaging the first body part

(Pl. 56.1 Statement ¶ 18; Ex. W at 40.) Claim 7 (issued claim 6) as originally filed read:

7. A percussive massage device comprising:

a housing,

an electrical source,

a motor positioned in the housing,

a switch for activating the motor, and

a push rod assembly operatively connected to the motor and configured to reciprocate in response [***4**] to activation of the motor.

(Ex. W at 41.)

By a January 24, 2020 Office Action, the U.S. Patent and Trademark Office patent examiner ("the examiner") initially rejected claims 1-6, 10-11, 13-15, and 20 as indefinite. As to claim 1, the examiner stated: "the language set forth in lines 11-13 regarding 'alternatively grasping' the second and third handle portions is unclear as it is not known if Applicant is intending to claim that the second and third handle portions are positively being grasped and providing a massage to the first body part or if this is an optional step that does not have to be performed." (Ex. P at 3.) The examiner also rejected a number of claims as unpatentable over prior art. (Pl. 56.1 Statement ¶ 22; Ex. P at 5-16.)

In an April 17, 2020 response to the Office Action, Therabody amended claim 1 of the application as follows⁷:

A method of using a percussive massage device, the method comprising the steps of:

obtaining the percussive massage device, wherein the percussive massage device includes a housing that includes first, second and third handle portions that cooperate to define a handle opening, an electrical source,

a motor positioned in the housing, a switch for activating the motor, and a push rod assembly operatively connected to the motor and configured to reciprocate in response to activation of the motor, **wherein the first handle portion defines a first axis, the second handle portion defines a second axis and the third handle portion defines a third axis, and wherein the first, second and third axes cooperate to form a triangle, wherein the first handle portion is generally straight, wherein the second handle portion is generally straight, and wherein the third handle portion is generally straight,**

activating the motor using the switch,

grasping the first handle portion,

massaging a first body part,

[alternatively] grasping the second handle portion and massaging the first body part, and

[alternatively] grasping the third handle portion and massaging the first body part.

(Pl. 56.1 Statement ¶¶ 23; Ex. I at 2.)

Claim 7 was amended as follows:

A percussive massage device comprising: a housing, **wherein the housing includes first, second and third handle portions that cooperate to define a handle opening, wherein the first handle portion defines a first axis, the second handle portion defines a second axis and the third handle portion defines a third axis, wherein the first, second and third axes cooperate to form a triangle, wherein the first handle portion is generally straight, wherein the second handle portion is generally straight, and wherein the third handle portion is generally straight, such that a user can grasp any of the first, second or third handle portions independently to use the percussive massage device,**

an electrical source,

a motor positioned in the housing,

a switch for activating the motor, and

a push rod assembly operatively connected to the motor and configured to reciprocate in response to activation of the motor.

(Ex. I at 3-4.) Tzumi characterizes those amendments as made "to overcome Patent Office rejections" [*5] and as requiring "all three handles to be graspable." (Def. 56.1 Statement ¶¶ 4.)

In response to the obviousness rejections, Therabody argued, based on the configuration of devices described in the prior art references, that "a person of ordinary skill in the art would not be motivated to modify and reconfigure the [prior art] Rix device using the teachings of [prior art patents and applications] Haas, Oberheim and Matre to arrive at [amended] claims 1 and 7" because the cited references do not disclose "separate handle portions, nor do they suggest that the alleged housings of the device can be grasped anywhere other than a single handle" and "no motivation or reasoning is provided in Rix or any of the references to modify Rix to include the claimed handle portion features and the Examiner is making these modifications in hindsight based on a reading of the teachings in the present application." (Pl. 56.1 Statement ¶¶ 24-25; Ex. I at 15, 17 (original emphasis omitted).)

The examiner ultimately agreed, stating in the Notice of Allowability that "[w]hile the ... prior art references of record are related to the claimed invention, they do not disclose, either alone or suggest in combination, the limitations discussed above and set forth in independent claims 1 [and] 7 ... without the use of impermissible hindsight." (Pl. 56.1 Statement ¶¶ 27; Ex. X at 4.)

2. The '064 Patent

The '064 Patent claims a "percussive therapy device." The patent issued on December 8, 2020. The application for the '064 Patent was filed on May 7, 2020 and assigned application number 16/869,402. It is a continuation-in-part of the '448 Patent. ('064 Patent at 1-2.) Relevant to the instant motion, claim 1 as originally filed read:

1. A percussive therapy device comprising:

a housing,

an electrical source,

a motor positioned in the housing,

a switch for activating the motor, and

a push rod assembly operatively connected to the motor and configured to reciprocate in response to activation of the motor.

(Pl. 56.1 Statement ¶ 30; Ex. Z at 72.)

Dependent claim 2 as originally filed read:

The percussive therapy device of claim [1] wherein the housing includes first, second and third handle portions and a head portion that cooperate to define a handle opening, wherein the first handle portion defines a first axis, the second handle portion defines a second axis and the third handle portion defines a third axis, wherein the first, second and third axes cooperate to form a triangle, wherein the motor is positioned in the head portion of the housing, and wherein at least a portion of the push rod assembly extends outside of the head portion.

(Pl. 56.1 Statement ¶ 31; Ex. Z at 72.) Claim 2 was amended in a preliminary amendment before examination on June 17, 2020 to read:

The percussive therapy device of claim [1] wherein the housing includes first, second and third handle portions and a head portion that cooperate to define a handle opening, wherein the first handle portion defines a first axis, the second handle portion defines a second axis and the third handle portion defines a third axis, wherein the first, second and third axes cooperate to form [*6] a triangle, ***such that a user can grasp any of the first, second or third handle portions independently to use the percussive therapy device***, wherein the motor is positioned in the head portion of the housing, and wherein at least a portion of the push rod assembly extends outside of the head portion.

(Ex. AA at 2 (emphasis showing amended language in original).)

Dependent claim 22 was added in the same preliminary amendment and read:

The percussive therapy device of claim 2 wherein the first handle portion includes a first handle

portion interior edge and defines a first handle portion length, **wherein the first handle portion length is long enough that when a user grasps the first handle portion with a hand at least a portion of three fingers extend through the handle opening** and contact the first handle portion interior edge, wherein the second handle portion includes a second handle portion interior edge and defines a second handle portion length, **wherein the second handle portion length is long enough that when a user grasps the second handle portion with a hand at least a portion of three fingers extend through the handle opening** and contact the second handle portion interior edge, wherein the third handle portion includes a third handle portion interior edge and defines a third handle portion length, **wherein the third handle portion length is long enough that when a user grasps the third handle portion with a hand at least a portion of three fingers extend through the handle opening** and contact the third handle portion interior edge.

(Pl. 56.1 Statement ¶ 32; Ex. AA at 4-5 (emphasis added.))

In a July 28, 2020 Office Action, the examiner rejected, inter alia, claim 1 of the '064 Patent Application "as being unpatentable over Rix (7,927,259) in view of Haas (2005/0126018)." (Pl. 56.1 Statement ¶ 33; Ex. BB at 6.)

In response, on September 1, 2020, Therabody amended claim 1 as follows:

A percussive therapy device comprising:

a housing, **wherein the housing includes first, second and third handle portions and a head portion that cooperate to define a handle opening, wherein the first handle portion defines a first axis, the second handle portion defines a second axis and the third handle portion defines a third axis, wherein the first, second and third axes cooperate to form a triangle, such that a user can grasp any of the first, second or third handle portions independently to use the percussive therapy device, and wherein the motor is positioned in the head portion of the housing,**

an electrical source,

a motor positioned in the housing,

a switch for activating the motor, and

a push rod assembly operatively connected to the motor and configured to reciprocate in response to activation of the motor.

(Pl. 56.1 Statement ¶ 36; Ex. J at 2.) Dependent claim 2 was amended to remove the language that was incorporated into claim 1. (Ex. J at 2-3.) Tzumi characterizes the amendment to claim 1 as adding "[t]he same basic requirement" that "required all three handles to be graspable." (See Def. 56.1 Statement ¶¶ 4-5.)

The examiner issued a Notice of Allowability for the '064 Patent [*7] on September 18, 2020, stating in part:

when read in light of the limitations of the claimed percussive therapy device/method, the prior art

does not disclose, either alone or in combination, a percussive therapy device including an electrical source, motor positioned in a head portion of a housing, a switch for actuation of the motor, a push rod assembly to reciprocate when actuated by the motor, the housing including a head portion and first, second, and third handle portions that define a handle opening and first, second, and third axes, respectively, which form a triangle such that the user can grasp any of the first, second, or third handle portions independently to use the device as set forth in independent claim 1.

(Pl. 56.1 Statement ¶ 37; Ex. CC at 4.)

3. The '565 Patent

The '565 Patent claims a "percussive massage device and method of use." The patent issued on February 16, 2021. The application for the '565 Patent was filed on July 2, 2020 and assigned application number 16/919, 588. It is a continuation-in-part of the '448 Patent. ('565 Patent at 1-2.) Relevant to the instant motion, claim 1 as originally filed read:

1. A percussive massage device comprising:

a housing, wherein the housing includes first, second and third handle portions that cooperate to at least partially define a handle opening, wherein the first handle portion defines a first axis, the second handle portion defines a second axis and the third handle portion defines a third axis, wherein the first handle portion is generally straight, wherein the second handle portion is generally straight, and wherein the third handle portion is generally straight, such that a user can grasp any of the first, second or third handle portions independently to use the percussive massage device,

an electrical source,

a motor positioned in the housing,

a switch for activating the motor, and

a push rod assembly operatively connected to the motor and configured to reciprocate in response to activation of the motor.

(Pl. 56.1 Statement ¶ 39; Ex. EE at 40.) Dependent claim 2 read:

The percussive massage device of claim 1 wherein the first handle portion includes a first handle portion interior edge and defines a first handle portion length, wherein the first handle portion length is long enough that when a user grasps the first handle portion with a hand at least a portion of three fingers extend through the handle opening and contact the first handle portion interior edge, wherein the second handle portion includes a second handle portion interior edge and defines a second handle portion length, wherein the second handle portion length is long enough that when a user grasps the second handle portion with a hand at least a portion of three

fingers extend through the handle opening and contact the second handle portion interior edge, wherein the third handle portion includes a third handle portion interior edge and defines a third handle portion length, wherein the third handle portion length is long enough that when a user grasps the third handle portion with a hand at least a portion [*8] of three fingers extend through the handle opening and contact the third handle portion interior edge.

(Pl. 56.1 Statement ¶ 41; Ex. EE at 40.)

In a September 22, 2020 Office Action, the examiner interpreted language in claims 1, 4, 12, and 13 as follows:

The claim limitation "a user can grasp any of the first, second, or third handle portions independently to use the percussive massage device" (claim 1 line 7-8, claim 4, claim 12 line 7-8, and claim 13) is being interpreted in light of the disclosure to mean that the each of the first, second, or third handle portions at any one time must be able to be grasped and used independently, such as shown in Figs. 16-18, and not interpreted as only one of the first, second, or third handle portions must be grasped and used individually. In other words, the claim limitation sets forth that each of the conditions shown in Fig. 16-18 is present in the claim and not that only at least one of is present in the claim.

(Ex. L at 2.) The examiner rejected claim 1 "as being anticipated by Pepe (2017/0304145)." (Ex. L at 3; see also Def. 56.1 Statement ¶ 6.)

In response, Therabody amended independent claim 1 to add the recitation "wherein the first, second and third axes are co-planar." (Pl. 56.1 Statement ¶ 44; Ex. M at 2; see also Def. 56.1 Statement ¶ 8.) Therabody argued that the requirement for the three axes of the handle portions to be co-planar "define[d] over Pepe" such that "the rejection should be withdrawn." (Ex. M at 14.) Dependent claim 2 was also amended to become independent claim 2, as follows:

[The percussive massage device of claim 1] ***A percussive massage device comprising:***

a housing, wherein the housing includes first, second and third handle portions that cooperate to at least partially define a handle opening, wherein the first handle portion defines a first axis, the second handle portion defines a second axis and the third handle portion defines a third axis, wherein the first handle portion is generally straight, wherein the second handle portion is generally straight, and wherein the third handle portion is generally straight, such that a user can grasp any of the first, second or third handle portions independently to use the percussive massage device, wherein the first handle portion includes a first handle portion interior edge and defines a first handle portion length, wherein the first handle portion length is long enough that when a user grasps the first handle portion with a hand at least a portion of three fingers extend through the handle opening and contact the first handle portion interior edge, wherein the second handle portion includes a second handle portion interior edge and defines a second handle portion length, wherein the second handle portion length is long enough that when a user grasps the second handle portion with a hand at least a portion of three fingers extend through the handle opening and contact the second

handle portion interior edge, wherein the third handle portion includes a third handle portion interior edge and defines a third handle portion length, wherein the third handle portion length [*9] is long enough that when a user grasps the third handle portion with a hand at least a portion of three fingers extend through the handle opening and contact the third handle portion interior edge,

an electrical source,

a motor positioned in the housing,

a switch for activating the motor, and

a push rod assembly operatively connected to the motor and configured to reciprocate in response to activation of the motor.

(Ex. M at 2-3 (emphasis showing amended language in original).)

A Notice of Allowability of the '565 Patent issued on January 8, 2021, stating in part:

[W]hen read in light of the limitations of the claimed percussive massage device/method of use, the prior art does not disclose, either alone or suggest in combination, a percussive massage device including a housing, electrical source, motor, switch, and push rod assembly, wherein the housing: a) includes first, second, and third generally straight handle portions that define a handle opening and first, second, and third axes, respectively, which are co-planar as set forth in independent claims 1 and 7; b) the handle portions each defining interior edge and lengths which allow for a user to grasp with a hand such that three fingers extend through the handle opening and contact the respective handle portion interior edge as set forth in independent claims 2, 8, and 12; c) the first, second, and third axes cooperate to form a triangle that surrounds the handle opening as set forth in independent claim 3 and 11.

(Pl. 56.1 Statement ¶ 45; Ex. N. at 3-4.)

4. The '722 Patent

The '722 Patent claims a "percussive massage device and method of use." The patent issued on November 2, 2021. The application for the '722 Patent was filed on February 4, 2021 and assigned application number 17/167,672. It is a continuation-in-part of the '565 Patent. ('722 Patent at 1-2.)

In a July 15, 2021 Office Action, the examiner interpreted certain claim limitation language similarly to the interpretation provided in regard to the '565 Patent application:

The claim limitation "a user can grasp any of the first, second, or third handle portions independently to use the percussive massage device" (claim 1 line 5-7, claim 6 line 5-7, claim 11 line 10-11, and claim 17 line 10-11) is being interpreted in light of the disclosure to mean that each of the first, second, or third handle portions at any one time must be able to be grasped and used independently, such as shown in Figs. 16-18, and not interpreted as only one of the first, second, or third handle portions must be grasped and used individually. In other words, the claim limitation

sets forth that each of the conditions shown in Figs. 16-18 is present in the claim and not that only at least one of the conditions is present in the claim.

(Ex. S at 4.)

The Notice of Allowability issued on September 22, 2021, after Therabody made amendments and arguments not related to the issues in this motion. As it did in response to each patent's Notice of Allowability, Therabody submitted comments on October 1, 2021, stating "to the extent that the Examiner has characterized the claims and/or the invention, characterized the prior [*10] art, paraphrased claim recitations, emphasized certain recitations over others, or otherwise made statements or notations purporting to limit the scope of the allowed claims, Applicant respectfully disagrees with any and all such statements and characterizations made by the Examiner." (Cf. Pl. 56.1 Statement ¶ 46; Ex. FF at 1.)

5. Accused Products

Therabody asserts percussive massage devices sold by Tzumi infringe on the four patents described above. As examples, Therabody accuses the FitRx Pro (denoted the "Second Infringing Device" in Therabody's complaint) and the ProFit Elite (the "Fourth Infringing Device"). The Accused Products are pictured below:



(SAC ¶ 35.) The feature at the core of the dispute on the instant motion is the alleged "second handle portion" identified by Therabody as exemplified below:



(SAC ¶ 61.) Tzumi, contends that the alleged second handle portion is not graspable and is not a handle at all, but merely a "transition section" that connects the two handles on the device:



(Def. 56.1 Statement ¶ 3.) According to Tzumi, the Accused Products do not infringe the asserted patents because only two of the handles are graspable. That argument, however, is premised on the claim construction that to be graspable, "[a]ll three handles must be of a length sufficient for a person with a large hand to firmly and comfortably grip each handle portion with at least three to four fingers extending through the opening." (Def. Mem. at 11.) Therabody disputes the limitation that Tzumi seeks to impose on the patent claims and contends that factual disputes preclude summary judgment of noninfringement under either Tzumi's construction or a plain-and-ordinary-meaning construction of the claim terms.

LEGAL STANDARDS

A. Summary Judgment Standard

To obtain summary judgment under Rule 56, the movant must show that there is no genuine dispute of material fact. Fed. R. Civ. P. 56(a). A fact is material if "the evidence is such that a reasonable jury could return a verdict for the nonmoving party." *Anderson v. Liberty Lobby, Inc.*, 477 U.S. 242, 248, 106 S. Ct. 2505, 2510 (1986). The moving party bears the initial burden of identifying "the absence of a genuine issue of material fact." *Celotex Corp. v. Catrett*, 477 U.S. 317, 323, 106 S. Ct. 2548, 2553 (1986). The opposing party must then come forward with specific materials establishing the existence of a genuine dispute; conclusory statements or mere allegations are not sufficient to defeat summary judgment. *Anderson*, 477 U.S. at 248, 106 S. Ct. at 2510; *Geyer v. Choinski*, 262 F. App'x 318, 318 (2d Cir. 2008). Where the nonmoving party "fails to make a showing sufficient to establish the existence of an element essential to that party's case, and on which that party will bear the burden of proof at trial," summary judgment must be granted. *Celotex*, 477 U.S. at 322, 106 S. Ct. at 2552; accord *El-Nahal v. Yassky*, 835 F.3d 248, 252 (2d Cir. 2016).

The moving party may demonstrate the absence of a genuine issue of material fact "in either of two ways: (1) by submitting evidence that negates an essential element of the non-moving party's claim, or (2) by demonstrating that the non-moving party's evidence is insufficient to establish an essential element of the non-moving party's claim." *Nick's Garage, Inc. v. Progressive Casualty Insurance Co.*, 875 F.3d 107, 114 (2d Cir.

[*11] 2017) (quoting *Farid v. Smith*, 850 F.2d 917 , 924 (2d Cir. 1988)). A party asserting that a fact cannot be or is genuinely disputed "must support the assertion by" either "citing to particular parts of materials in the record" or "showing that the materials cited do not establish the absence or presence of a genuine dispute, or that an adverse party cannot produce admissible evidence to support the fact." Fed. R. Civ. P. 56(c)(1) ; see also *Powell v. National Board of Medical Examiners*, 364 F.3d 79 , 84 (2d Cir. 2004) ("if the movant demonstrates an absence of a genuine issue of material fact," the nonmovant bears the burden of demonstrating "more than some metaphysical doubt as to the material facts" and pointing to "specific facts showing that there is a genuine issue for trial" (internal quotation marks and citations omitted)).

In assessing the record to determine whether there is a genuine issue of material fact, a court must resolve all ambiguities and draw all factual inferences in favor of the nonmoving party. *Anderson*, 477 U.S. at 255 , 106 S. Ct. at 2513 ("[t]he evidence of the non-movant is to be believed, and all justifiable inferences are to be drawn in his favor"); *Smith v. Barnesandnoble.com, LLC*, 839 F.3d 163 , 166 (2d Cir. 2016) ("we view the evidence in the light most favorable to the party opposing summary judgment, draw all reasonable inferences in favor of that party, and eschew credibility assessments") (alterations and citation omitted); *Sutera v. Schering Corp.*, 73 F.3d 13 , 16 (2d Cir. 1995) ("The district court must draw all reasonable inferences and resolve all ambiguities in favor of the nonmoving party and grant summary judgment only if no reasonable trier of fact could find in favor of the nonmoving party"). At the same time, the court must inquire whether "there is sufficient evidence favoring the nonmoving party for a jury to return a verdict for that party." *Anderson*, 477 U.S. at 249 , 106 S. Ct. at 2511 . Summary judgment may be granted "where the nonmovant's evidence is conclusory, speculative, or not significantly probative." *Zeno v. Pine Plains Central School District*, No. 07-CV-6508, [2009 BL 109712], 2009 WL 1403935 , at *2 (S.D.N.Y. May 20, 2009) (citing *Anderson*, 477 U.S. at 249-50 , 106 S. Ct. at 2510-11); see *Matsushita Electric Industrial Co. v. Zenith Radio Corp.*, 475 U.S. 574 , 586 , 106 S. Ct. 1348 , 1356 (1986) (finding that, if there is nothing more than a "metaphysical doubt as to the material facts," summary judgment is proper).

These standards are equally applicable in patent cases as in any other case. *Desper Products, Inc. v. QSound Labs, Inc.*, 157 F.3d 1325 , 1332 (Fed. Cir. 1998); accord *NeuroGrafix v. Brainlab, Inc.*, 787 F. App'x 710 , 716-18 (Fed. Cir. 2019) (applying *Celotex* to motion for summary judgment of noninfringement); *Exigent Technology, Inc. v. Atrana Solutions, Inc.*, 442 F.3d 1301 , 1307-09 (Fed. Cir. 2006) (same). For example, "[s]ummary judgment is appropriate when it is apparent that only one conclusion as to infringement could be reached by a reasonable jury" or where "the patent owner's proof is deficient in meeting an essential part of the legal standard for infringement, since such failure will render all other facts immaterial." *Telemac Cellular Corp. v. Topp Telecom, Inc.*, 247 F.3d 1316 , 1323 (Fed. Cir. 2001).

B. Patent Infringement Principles

Analysis of alleged patent infringement has two steps: first, the Court construes the asserted patent claims; second, the construed claims are compared to the accused devices or methods [*12] to determine if infringement has occurred. See *Markman v. Westview Instruments, Inc.*, 517 U.S. 370 , 384 , 116 S. Ct. 1384 , 1393 (1996); accord *Niazi Licensing Corp. v. St. Jude Medical S.C., Inc.*, 30 F.4th 1339 , 1350 (Fed. Cir. 2022).

1. Claim Construction

Claim construction is a question of law decided by the Court, although it may require resolving underlying factual disputes. *See, e.g., Techtronic Industry Co. v. International Trade Commission*, 944 F.3d 901 , 906 (Fed. Cir. 2019); *Shire Development, LLC v. Watson Pharmaceuticals, Inc.*, 787 F.3d 1359 , 1364 (Fed. Cir. 2015).

When construing claims, "[i]t is the claims that define the metes and bounds of the patentee's invention." *Thorner v. Sony Computer Entertainment America LLC*, 669 F.3d 1362 , 1367 (Fed. Cir. 2012). "Claim terms are generally given their ordinary and customary meaning," and "the ordinary and customary meaning of a claim term is the meaning that the term would have to a person of ordinary skill in the art." *Ventana Medical Systems, Inc. v. Biogenex Laboratories, Inc.*, 473 F.3d 1173 , 1180 (Fed. Cir. 2006) (internal quotation marks and citations omitted). "[T]he person of ordinary skill in the art is deemed to read the claim term not only in the context of the particular claim in which the disputed term appears, but in the context of the entire patent, including the specification." *Phillips v. AWH Corp.*, 415 F.3d 1303 , 1313 (Fed. Cir. 2005).

Exceptions to the ordinary and customary meaning rule are "1) when a patentee sets out a definition and acts as his own lexicographer, or 2) when the patentee disavows the full scope of a claim term either in the specification or during prosecution." *Thorner*, 669 F.3d at 1367 . "To act as its own lexicographer, a patentee must 'clearly set forth a definition of the disputed claim term' other than its plain and ordinary meaning." *Id.* (quoting *CCS Fitness, Inc. v. Brunswick Corp.*, 288 F.3d 1359 , 1366 (Fed. Cir. 2002)). Disavowal of claim scope requires that "the specification [or prosecution history] make[] clear that the invention does not include a particular feature." *GE Lighting Solutions, LLC v. AgiLight, Inc.*, 750 F.3d 1304 , 1309 (Fed. Cir. 2014) (quoting *SciMed Life Systems Inc. v. Advanced Cardiovascular Systems, Inc.*, 242 F.3d 1337 , 1341 (Fed. Cir. 2001)). But even absent disavowal, "[a]ny explanation, elaboration, or qualification presented by the inventor during patent examination is relevant, for the role of claim construction is to 'capture the scope of the actual invention' that is disclosed, described, and patented." *Iridescent Networks, Inc. v. AT&T Mobility, LLC*, 933 F.3d 1345 , 1352-53 (Fed. Cir. 2019) (quoting *Fenner Investments, Ltd. v. Cellco Partnership*, 778 F.3d 1320 , 1323 (Fed. Cir. 2015)).

While in some cases, "the ordinary meaning of claim language as understood by a person of skill in the art may be readily apparent even to lay judges, and claim construction in such cases involves little more than the application of the widely accepted meaning of commonly understood words," these cases are the minority. *Phillips*, 415 F.3d at 1314 . In most cases, the Court must look to "those sources available to the public that show what a person of skill in the art would have understood disputed claim language to mean," including "the words of the claims themselves, the remainder of the specification, the prosecution history, and extrinsic evidence concerning relevant scientific principles, the meaning of technical terms, [*13] and the state of the art." *Id.* (internal quotation marks and citations omitted).

Courts "look primarily to the intrinsic evidence including the claim language, written description, and prosecution history." *Lucent Technologies, Inc. v. Gateway, Inc.*, 525 F.3d 1200 , 1206 (Fed. Cir. 2008) (citing *Phillips*, 415 F.3d at 1312-17). "Other claims of the patent in question, both asserted and unasserted, can also be valuable sources of enlightenment as to the meaning of a claim term" and "[d]ifferences among claims can also be a useful guide in understanding the meaning of particular claim terms." *Phillips*, 415 F.3d at 1314 . Extrinsic evidence, "which consists of all evidence external to the patent and prosecution history, including

expert and inventor testimony, dictionaries, and learned treatises ... is less significant than the intrinsic record in determining the legally operative meaning of claim language." *Id.* at 1317 (internal quotation marks and citations omitted).

"[A]lthough the claims are construed objectively and without reference to the accused device, only those terms need be construed that are in controversy, and only to the extent necessary to resolve the controversy." *Vivid Technologies Inc. v. American Science & Engineering Inc.*, 200 F.3d 795 , 803 (Fed. Cir. 1999); *accord Eon Corp. IP Holdings v. Silver Spring Networks*, 815 F.3d 1314 , 1319 (Fed. Cir. 2016) ("a district court's duty at the claim construction stage is ... to resolve a dispute about claim scope that has been raised by the parties").

2. Infringement

A patent may be infringed by "literal infringement" or under the "doctrine of equivalents." Literal infringement requires that "every limitation recited in the claim is found in the accused device." *EMED Technologies Corporation v. Repto-Med Systems, Inc.*, 809 F. App'x 885 , 890 (Fed. Cir. 2020) (quoting *Akzo Nobel Coatings, Inc. v. Dow Chemical Co.*, 811 F.3d 1334 , 1341 (Fed. Cir. 2016)).

By comparison, "[a] finding of infringement under the doctrine of equivalents requires a showing that the difference between the claimed invention and the accused product or method [is] insubstantial or that the accused product or method performs substantially the same function in substantially the same way with substantially the same result as each claim limitation of the patented product or method." *Plastic Omnium Advanced Innovation & Research v. Donghee America, Inc.*, 943 F.3d 929 , 938 (Fed. Cir. 2019) (quoting *AquaTex Industries, Inc. v. Techniche Solutions*, 479 F.3d 1320 , 1326 (Fed. Cir. 2007)). "The function, way, result inquiry focuses on an examination of the claim and the explanation of it found in the written description of the patent." *Id.*

A patentee may be foreclosed from relying on the doctrine of equivalents, however, by prosecution history estoppel, whereby "the surrender of subject matter during patent prosecution creates a presumption that the patentee is precluded from recapturing that subject matter through the doctrine of equivalents." *AquaTex Industries, Inc.*, 479 F.3d at 1325 .

DISCUSSION

Tzumi's motion should be denied. As discussed in Section A below, Tzumi's motion is not procedurally improper, as Therabody argues, but nonetheless, the motion does not satisfy the requirements for granting summary judgment on Tzumi's proposed claim construction. [*14] As explained in Section B, Tzumi's construction should be rejected because it is inconsistent with other claims in the asserted patents, imports limitations from the specification into the claims, and relies on speculation concerning the prosecution history. Although Tzumi's motion therefore should be denied, Therabody has not cross-moved for summary judgment on a proposed alternative construction of the "grasp[ing]" claims. As set forth in Section C, the Court recommends that construction of what the "grasp[ing]" claims actually require be decided on a more developed record and in accordance with the Court's schedule for determining claim construction.

A. The Extent To Which Tzumi's Motion Is Premature

Therabody contends that Tzumi's motion for partial summary judgment is premature, particularly given the schedule that the parties' jointly proposed and the Court so-ordered. Therabody further asserts that Tzumi's motion does not clearly identify the words to be construed, is entirely without factual support, and would not resolve the case. (Pl. Mem. at 12-13.¹⁰)

The Court agrees that Tzumi's bid for early summary judgment on claim construction and non-infringement is somewhat at odds with the schedule adopted. After all, Tzumi three times joined in proposing dates that contemplated claim construction unfolding at a much more measured pace after other steps. That said, Tzumi did raise its desire to file an early summary judgment motion on March 18, 2022, almost two weeks before the parties jointly filed the proposed schedule ultimately adopted. The Court cannot fault Tzumi for following through with filing the proposed motion for which the Court set a briefing schedule.

Moreover, Tzumi asserts that resolution of the instant claim construction and infringement issue — in its favor — would resolve the case as to the Accused Products that make up as much as 90 percent of the product sales at issue and would, thereby, effectively lead to complete resolution of the case. (Def. Mem. at 1.) Narrowing issues in such fashion is one of the potential benefits of moving for early partial summary judgment. *See Luv N' Care, Ltd. v. Regent Baby Products Corp.*, No. 10-CV-9492, [2014 BL 39194], 2014 WL 572524, at *1 (S.D.N.Y. Feb. 13, 2014) (discussing "significant narrowing of the issues as a result of ... the partial summary judgment ruling"); *Schanker & Hochberg, P.C. v. Berkley Assurance Co.*, 589 F. Supp. 3d 281, 297 (E.D.N.Y. 2022) ("A district court may grant partial summary judgment to streamline the litigation process by narrowing the triable issues" (internal quotation marks omitted)); Edward Brunet, John Parry, & Martin Redish, Summary Judgment: Federal Law and Practice § 3:2 (2022 ed., Dec. 2021) ("[p]artial adjudications' are 'valuable devices for defining, narrowing, and focusing the issues to be litigated, thus conserving judicial resources'" (quoting William W. Schwarzer, Alan Hirsch & David J. Barrans, *The Analysis and Decision of Summary Judgment Motions*, 139 F.R.D. 441, 496 (1992).)

It thus is not unheard of to decide claim construction and noninfringement in an early summary judgment motion. *See, e.g., Choon's Design, LLC v. Idea Village Products Corp.* [*15], 776 F. App'x 691, 696 (Fed. Cir. 2019) (affirming district court's early claim construction and summary judgment of noninfringement where the claims could be properly construed based on the intrinsic evidence and where no reasonable jury could find that the accused device performed the same function as that claimed by the patent-in-suit); *Innovad Inc. v. Microsoft Corp.*, 260 F.3d 1326, 1335-36 (Fed. Cir. 2001) (affirming district court's pre-discovery claim construction and grant of summary judgment of noninfringement and finding that the "dialer unit" claimed in the patent at issue could not include a keypad, and because the dialer unit of the accused devices did include a keypad, the accused devices could not infringe).

Even so, the cases where summary judgment has been found appropriate before discovery typically are those in which the claim construction advanced by the movant was supported entirely by the intrinsic evidence (as Tzumi contends but Therabody disputes) and in which there were no factual disputes. *See, e.g., Choon's Design, LLC*, 776 F. App'x at 696-97 (affirming summary judgment of noninfringement where "Choon's does not contest that IdeaVillage's product lacks reconfigurable pins," allowing the Court to determine as a matter of law that the product does not infringe literally or under the doctrine of equivalents); *Innovad, Inc.*, 260 F.3d at 1335 ("As pointed out by the district court, '[Innovad] does not dispute that each of the accused hand-held

computers has an integral keyboard with numeric keypad that may be used to delete, edit, or replace any stored phone number").

In contrast, as will be discussed below, Tzumi's proposed claim construction is not indisputably established by the intrinsic evidence provided. And even if the proposed claim construction were proper, Therabody emphatically does not concede facts that would compel a judgment of noninfringement under Tzumi's construction. (See, e.g., Pl. Mem. at 21-24 (detailing factual disputes regarding the Accused Products); Pl. 56.1 Statement at 2-3 (disputing Tzumi's contentions that the Accused Products have only two handles and that the transitional section has no linear dimension), 4-11 (disputing Tzumi's characterization of the prosecution history).)

Tzumi argues in reply that Therabody failed to meet the requirements of Rule 56(d) to move for additional discovery,¹¹ and could have provided expert evidence regarding relevant factual disputes. (Def. Reply at 9.¹²) But Therabody's briefing does not invoke Rule 56(d) or rest its opposition on the lack of information available to it. Instead, Therabody affirmatively rejects Tzumi's claim construction, while also pointing out the existence of factual disputes even if that claim construction were accepted.

In such circumstances, summary judgment should be denied. See *Mirror Worlds Technologies, LLC v. Facebook, Inc.*, 800 F. App'x 901, 910 (Fed. Cir. 2020) ("When Facebook moved for summary judgment ... before discovery closed, its attempt to 'show' entitlement to summary judgment rested on one assertion: that TAO does not store information in a time-ordered sequence," and because Plaintiff adequately disputed that assertion, [*16] summary judgment of noninfringement was inappropriate); see also *id.* at 909 ("The Second Circuit has explained that 'when a defendant moves for summary judgment, it is the *defendant* who must show entitlement to judgment, notwithstanding that, at trial, the plaintiff will have the burden of proving every element of its claim") (quoting *Nick's Garage*, 875 F.3d at 115); *NeuroGrafix*, 787 F. App'x at 717 (denying motion for summary judgment of noninfringement was warranted where "[Plaintiff] demonstrated that there was a genuine dispute of material fact on the only issue raised by [Defendant]").

B. Tzumi Has Not Indisputably Established Its Proposed Construction Of The "Grasping" Limitations

Tzumi states in its opening brief that "this motion requires interpretation of a single word ('grasp')" and identifies which claim limitations it believes should be construed pursuant to its proposed construction. (Def. Mem. at 9; see also Def. Mem. at 11 (identifying the "grasping limitations").) The Court therefore approaches its analysis with the understanding that "grasp(ing)" is the term to be construed, and that Tzumi asks the Court to construe limitations in fifteen claims that require "grasp[able]" handles to mean that "[a]ll three handles must be of a length sufficient for a person with a large hand to firmly and comfortably grip each handle portion with at least three to four fingers extending through the opening." (Def. Mem. at 11.) Tzumi argues that this construction is supported by the specification and compelled by the prosecution history. For the reasons that follow, the Court disagrees.

1. Tzumi Fails To Address The Term "Grasp" Itself

As noted earlier, a claim term generally is deemed to have its "ordinary and customary meaning." *Ventana Medical Systems, Inc.*, 473 F.3d at 1180. Tzumi has not put forward any evidence that the ordinary and

customary meaning of "grasping" a handle to a person of ordinary skill in the art would mean having a handle that is "of a length sufficient for a person with a large hand to firmly and comfortably grip each handle portion with at least three to four fingers extending through the opening." Nor has Tzumi submitted any industry source or dictionary definition that defines "grasp" or "graspable" in anything approaching the detailed meaning that Tzumi ascribes to the term. *Cf.* Ex. GG (reflecting the Britannica Dictionary's definition of "grasp" means "to take and hold (something) with your fingers, hands, etc.").

Nor do the patents indicate that the patentees set out any special definition of "graspable." To do so, the patentees would have had to "clearly set forth a definition of the disputed claim term other than its plain and ordinary meaning." *Thorner*, 669 F.3d at 1365 (internal quotation marks and citations omitted). None of the patents clearly define grasp or its variants to have any special definition. The patentees certainly knew how to do so if they wanted to; indeed, they employed the term "means" or "to mean" for exactly that purpose. (See, e.g., '448 Patent at 2:23-27 ("generally straight means ..."), 6:32-36 ("Reference in this specification to 'one embodiment' or 'an embodiment' means ..."), 20:52-57 ("As used herein, the terms [*17] 'connected,' 'coupled,' or any variant thereof, means ..."). The Court thus finds no basis to conclude that the patentees specially defined "grasp" to have the meaning that Tzumi's construction gives it.

2. Tzumi's Proposed Construction Would Impermissibly Result In Independent Claims Narrower Than Their Dependent Claims

Looking beyond the specific term to the claims in which the term appears, none of the asserted **independent** claims specify the length of the handles claimed, much less define that to be grasped the handles must be "of a length sufficient for a person with a large hand to firmly and comfortably grip each handle portion with at least three to four fingers extending through the opening." In contrast, limitations describing the length of handles and how many fingers extend through the handle opening in the claimed device are set forth in a variety of **dependent** claims in the asserted patents. Limitations describing a "firm and comfortable grip" are entirely absent from the asserted claims.

Tzumi's proposed construction should be rejected because it would result in independent claims with a narrower scope than claims that depend from them. "Under the doctrine of claim differentiation, each claim in a patent is presumptively different in scope." *Wenger Manufacturing, Inc. v. Coating Machinery Systems, Inc.*, 239 F.3d 1225, 1233 (Fed. Cir. 2001). While "claim differentiation is not a hard and fast rule of construction, and cannot be relied upon to broaden claims beyond their correct scope," the doctrine "is clearly applicable when there is a dispute over whether a limitation found in a dependent claim should be read into an independent claim." *Id.* (internal quotation marks and citation omitted).

"By definition, an independent claim is broader than a claim that depends from it." *Littelfuse, Inc. v. Mersen USA EP Corp.*, 29 F.4th 1376, 1380 (Fed. Cir. 2022). A claim construction otherwise would mean that "the dependent claims would have no scope and thus be meaningless," which is "generally disfavored." *Id.* (collecting cases); *accord Intamin Ltd. v. Magnetar Technologies, Corp.*, 483 F.3d 1328, 1335 (Fed. Cir. 2007) ("An independent claim impliedly embraces more subject matter than its narrower dependent claim"); *Wright Medical Technology, Inc. v. Osteonics Corp.*, 122 F.3d 1440, 1445 (Fed. Cir. 1997) (rejecting claim construction that would render an independent claim narrower than a dependent claim because "we must not

interpret an independent claim in a way that is inconsistent with a claim which depends from it").

Tzumi's construction of the "grasping" limitations violates that fundamental principle. For example, Tzumi construes the "grasping" limitation of claim 1 of the '448 Patent to require that "[a]ll three handles must be of a length sufficient for a person with a large hand to **firmly and comfortably grip** each handle portion with **at least three to four fingers extending through the opening.**" (Def. Mem. at 11 (emphasis added).) Claim 1 contains no such language. In contrast, claim 2 of the '448 Patent, which depends from claim 1, discloses:

The method of claim 1 wherein the first handle portion includes a first handle portion interior [*18] edge and defines a first handle portion length, wherein the first handle portion length **is long enough that when a user grasps the first handle portion with a hand at least a portion of three fingers extend through the handle opening and contact the first handle portion interior edge**, wherein the second handle portion includes a second handle portion interior edge and defines a second handle portion length, wherein the second handle portion **length is long enough that when a user grasps the second handle portion with a hand at least a portion of three fingers extend through the handle opening and contact the second handle portion interior edge**, wherein the third handle portion includes a third handle portion interior edge and defines a third handle portion length, **wherein the third handle portion length is long enough that when a user grasps the third handle portion with a hand at least a portion of three fingers extend through the handle opening and contact the third handle portion interior edge.**

('448 Patent, 22:49-67 (emphasis added).) Tzumi's construction of "grasping" in claim 1 to require a firm and comfortable grip with three to four fingers extending through the handle opening is narrower than claim 2's disclosure of only a portion of three fingers extending through the opening and merely contacting the interior edge, counseling against adoption of Tzumi's construction. Similar issues exist regarding other asserted claims. (See, e.g., '448 Patent claims 6 and 7; '064 Patent claims 1 and 9; '565 Patent claims 1 and 6-7; '722 Patent claims 1 and 4.)

While claim differentiation is only a presumption, Tzumi's arguments fall short of rebutting that presumption. (See Def. Reply at 2.) First, while the dependent claims arguably add additional limitations not encompassed by Tzumi's construction, Tzumi does not reconcile how, for example, the limitation in claim 2 that only a portion of three fingers extend through the handle opening and merely contact the interior edge in a dependent claim would not be rendered meaningless by the limitation in claim 1, as construed by Tzumi, that three to four fingers must extend through the handle opening in a comfortable and firm grip. While Tzumi is correct that claim differentiation may not apply where the dependent claims actually do claim distinct subject matter, it fails to grapple with this clear conflict.¹³

Tzumi is correct in principle that the presumption of claim differentiation may be overcome by clear intrinsic evidence to the contrary. But Tzumi's construction is not clearly supported by the specification or prosecution history as further explained below. It therefore fails to overcome the presumption disfavoring a construction that renders dependent claims meaningless by virtue of a narrower independent claim. See, e.g., *Littelfuse*, 29 F.4th at 1380 (rejecting Defendant's argument that the presumption of claim differentiation need not apply

because Defendant's "construction would not merely render the dependent claims superfluous, but would mean that those claims would [*19] have no scope at all, a result that should be avoided when possible"); accord *Ortho-McNeil Pharmaceutical, Inc. v. Mylan Laboratories, Inc.*, 520 F.3d 1358 , 1362 (Fed. Cir. 2008) ("[T]his court strives to reach a claim construction that does not render claim language in dependent claims meaningless").

3. Tzumi's Proposed Construction Improperly Imports Limitations From The Specification Into The Claims

The Court next considers the patent specification. Tzumi contends that several passages from the specification common to all four patents provide "clear and consistent descriptions of grasping handles" that support its proposed construction. (Def. Mem. at 12.) But rather than **define** what length of handle and number of fingers must be involved in "grasping" handles of the claimed devices, those passages merely describe **embodiments** of the invention.

The passages of the specification cited by Tzumi are devoid of language, like "'the present invention includes ...' or 'the present invention is ...' or 'all embodiments of the present invention are...,'" which would indicate disavowal of subject matter not encompassed by the described embodiment. *GE Lighting Solutions, LLC* 750 F.3d at 1309 (collecting cases). The specification does not "require" handles that can be "firmly and comfortably gripped with three or four fingers through the handle opening" or with certain dimensions, and it does not disparage alternative embodiments as would suggest that embodiments other than those described are not within the scope of the claims. See *Bayer Healthcare LLC v. Baxalta Inc.*, 989 F.3d 964 , 974-75 (Fed. Cir. 2021) (affirming claim construction that included non-random amine/lysine PEGylation because the specification "nowhere disparages non-random, site-directed amine/lysine PEGylation at the B-domain," and distinguishing cases finding disparagement in the specification); *Indivior Inc. v. Dr. Reddy's Laboratories, S.A.*, 930 F.3d 1325 , 1338 (Fed. Cir. 2019) (limiting claim scope based on "the specification's unambiguous disparagement of conventional top air drying"). And, as discussed earlier, the specification does not "clearly set forth a definition of the disputed claim term other than its plain and ordinary meaning" or "clearly express an intent to redefine the term," as needed for a patentee to "act as its own lexicographer." *Hill-Rom Services, Inc. v. Stryker Corp.*, 755 F.3d 1367 , 1371 (Fed. Cir. 2014) (quoting *Thorner*, 669 F.3d at 1365). The lack of disavowal and defined lexicography counsels against Tzumi's construction.¹⁴

Tzumi places particular emphasis on certain figures, and description of those figures in the specification. The particular language reads: "FIGS. 16-18 show a user's hand grasping the various handle portions. The length of each of the first, second and third handle portions is long enough so that a person with a large hand can comfortably grasp each handle portion with at least three to four fingers extending through the handle opening, as shown in FIGS. 16-18."¹⁵ (448 Patent at 16:38-43.) Figures 16-18 are reproduced below:

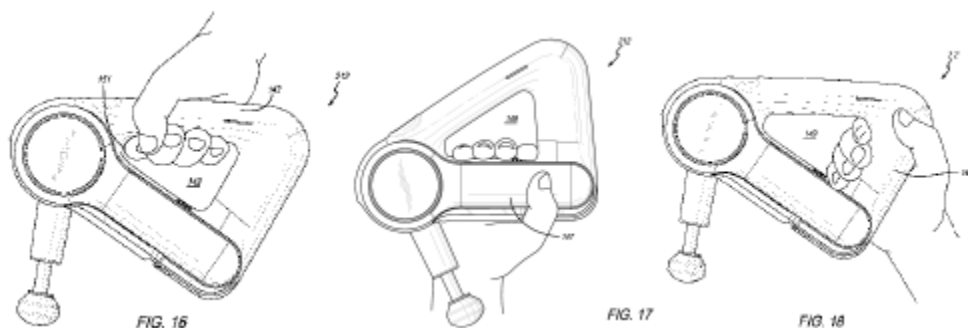

Considered in a vacuum, the passage and figures alone could perhaps be construed as limiting what it means to "grasp" a handle of the device. However, [*20] Tzumi overlooks language just prior to the passage clearly indicating that the figures and descriptions merely discuss potential embodiments of the claimed invention, rather than define any claim limitations.

Prior to the passage cited, the specification notes that " FIGS. 14-27 show further embodiments of the present invention. Many of the components of the reciprocal treatment devices or percussive massage devices of FIGS. 14-27 are the same or similar as those discussed above with respect to reciprocal treatment device 100. Accordingly, the description hereinafter focuses on components that are different." ('448 Patent at 16:9-14.) The passage cited by Tzumi is part of the "description hereinafter" that discusses components of the further embodiments not addressed earlier in the specification. The specification additionally states that " FIGS. 14-23 show **an embodiment** of a percussive massage device 212 that includes a rechargeable battery (and replaceable or removable battery) 114." ('448 Patent at 16:15-17 (emphasis added).)

Rather than clearly define what is needed to "grasp," the passage and figures identified by Tzumi demonstrate possible embodiments of the subject matter covered by the claims. Tzumi's argument would have this Court import limitations from the embodiments in the specification into the claims themselves, which the Court may not do. *See Phillips*, 415 F.3d at 1323 ("although the specification often describes very specific embodiments of the invention, we have repeatedly warned against confining the claims to those embodiments"); *accord Seachange International, Inc. v. C-COR, Inc.*, 413 F.3d 1361, 1377 (Fed. Cir. 2005) ("we do not import limitations from a preferred embodiment"); *GE Lighting Solutions, LLC*, 750 F.3d at 1309-10 (rejecting construction that imported limitations from the specification into claims where the specification described the features a part of a "depicted embodiment" and not as "the present invention, as essential, or as important" and without disparaging alternative embodiments).

Tzumi's other examples fare no better. At one juncture, the specification of the '448 Patent states "[i]t will be appreciated that these dimensions [of the handles] are optimized so that a 95th percentile male can grip any of the three handle portions with at least three and preferably four fingers extending through the handle opening to utilize the device" ('448 Patent 17:16-20.), and Fig. 14A and the description at 16:66-17:1 provide certain dimensions for the length of handle portions. Once again, however, Tzumi takes a passage of the specification out of context. Tzumi omits the language at the beginning of the paragraph noting that " FIG. 14A shows the **preferred** dimensions of the interior surfaces of the handle opening 149." ('448 Patent 16:62-63 (emphasis added).) Noting that the dimensions are "preferred" suggests that they are not the **only** dimensions of the handle opening that would be covered by the claims. Because "it is improper to read limitations from a preferred embodiment described in the specification ... into the claims absent a clear indication in the [*21]

intrinsic record that the patentee intended the claims to be so limited," Tzumi's construction of the grasping limitations cannot be adopted. *Liebel-Flarsheim Co. v. Medrad, Inc.*, 358 F.3d 898 , 913 (Fed. Cir. 2004).

Finally, while "a patentee [can define] a term 'by implication' where the patentee use[s] the term throughout the specification in a way that was consistent with only one meaning," *Info-Hold, Inc. v. Applied Media Technologies Corp.*, 783 F.3d 1262 , 1267 (Fed. Cir. 2015), the patentee in this case does no such thing. In all of Tzumi's cited examples, the patentee describes the handles and grasping somewhat differently. Those varying descriptions — sometimes not mentioning fingers or dimensions at all; sometimes requiring four fingers, while other times requiring three or four; sometimes prescribing specific dimensions for the handles; only once mentioning what might be a large hand; and never discussing the firmness or comfort of the grip — all specifically described as possible embodiments of the invention, are not consistent with the single meaning of the grasping limitations proposed by Tzumi. *See, e.g., Johnson Worldwide Associates, Inc. v. Zebco Corp.*, 175 F.3d 985 , 991 (Fed. Cir. 1999) ("Varied use of a disputed term in the written description demonstrates the breadth of the term rather than providing a limited definition"); *cf. Amazin' Raisins International, Inc. v. Ocean Spray Cranberries, Inc.*, 306 F. App'x 553 , 557 (Fed. Cir. 2008) (finding a claim term was defined by implication where "the passage at issue announce[d] the scope of the detailed description of the invention and precedes all other discussion of any embodiments or examples" and "the specification contain[ed] no varied usage or ambiguity").

4. Tzumi's Proposed Construction Is Not Compelled By The Prosecution History

To support its claim construction, Tzumi also seizes upon the prosecution history of the patents-in-suit, and, in particular, statements made by the examiner, as well as arguments and amendments made or accepted by Therabody. But neither the examiner's statements nor Therabody's arguments and amendments to overcome obviousness rejections indisputably support Tzumi's construction of the grasping limitations, and they do not indisputably establish Therabody's "disavow[al] [of] the full scope of [the "grasping"] claim term ... during prosecution." *Thorner*, 669 F.3d at 1365 .

a. The Examiner's Claim Interpretation

Tzumi argues that the examiner's interpretation of the claims, acquiesced to by Therabody as applicant, supports its construction. (Def. Mem. at 13.) In particular, Tzumi references an office action dated September 22, 2020, in which the examiner interpreted "[t]he claim limitation 'a user can grasp any of the first, second, or third handle portions independently to use the percussive massage device' (claim 1 line 7-8, claim 4, claim 12 line 7-8, and claim 13) ... in light of the disclosure to mean that the each of the first, second, or third handle portions at any one time must be able to be grasped and used independently, such as shown in Figs. 16-18." (Ex. L at 2.) Because Figs. 16-18 show a device with a handle long enough to be grasped with four fingers extending through the opening, [*22] Tzumi argues that the examiner and the patentee must have understood the grasping limitations to require such a handle. (Def. Mem. at 13.) But Tzumi overlooks the full context of the examiner's statement.

Tzumi suggests that the examiner interpreted some of the grasping limitations to require "all conditions" present in Figs. 16-18 of the specification, which from the drawings indicates a handle long enough for a hand to grip each handle portion with four fingers extending through the handle opening. But Tzumi reads more into

the examiner's interpretation than is warranted. With excised portions of the passage restored, the examiner understood as follows:

The claim limitation "a user can grasp any of the first, second, or third handle portions independently to use the percussive massage device" ... is being interpreted in light of the disclosure to mean that each of the first, second, or third handle portions at any one time must be able to be grasped and used independently, such as shown in Figs. 16-18, and not interpreted as only one of the first, second, or third handle portions must be grasped and used individually. In other words, the claim limitation sets forth that each of the conditions shown in Figs. 16-18 is present in the claim and not that only at least one of the conditions is present in the claim.

(Ex. L at 2; *see also* Ex. S at 4.)

As is clear from the full context of the passage, the examiner's mention of "each of the conditions" refers only to the ability of all three handles to be grasped and used independently, as opposed to the alternative that only at least one of the first, second, or third handle portions could be grasped to use the device. Nothing in the examiner's interpretation defines what it means to grasp and use the device, and no part of the interpretation defines a particular length or number of fingers that must extend through the opening, the size of the hand that need be accommodated by the handle opening, or the firmness or comfort of the grip required in order to "grasp" and use each handle.

b. Distinguishing Prior Art And Claim Amendments

"The doctrine of prosecution disclaimer preclud[es] patentees from recapturing through claim interpretation specific meanings disclaimed during prosecution" and "promotes the public notice function of the intrinsic evidence and protects the public's reliance on definitive statements made during prosecution." *Genuine Enabling Technology LLC v. Nintendo Co., Ltd.*, 29 F.4th 1365 , 1374 (Fed. Cir. 2022) (internal quotations and citation omitted.) "The party seeking to invoke prosecution history disclaimer bears the burden of proving the existence of a clear and unmistakable disclaimer that would have been evident to one skilled in the art." *Id.* (quoting *Massachusetts Institute of Technology v. Shire Pharmaceuticals, Inc.*, 839 F.3d 1111 , 1119 (Fed. Cir. 2016)).

"Where the alleged disavowal is ambiguous, or even 'amenable to multiple reasonable interpretations,' [the Federal Circuit has] declined to find prosecution disclaimer." *Avid Technology, Inc. v. Harmonic, Inc.*, 812 F.3d 1040 , 1045 (Fed. Cir. 2016) (quoting *Cordis Corp. v. Medtronic AVE, Inc.*, 339 F.3d 1352 , 1359 (Fed. Cir. 2003)). [*23] While "the prosecution history can often inform the meaning of the claim language by demonstrating how the inventor understood the invention" even without meeting the standard for disclaimer, *Phillips*, 415 F.3d at 1317 , it is "'less useful for claim construction purposes' than the claim language and written description." *SAS Institute, Inc. v. ComplementSoft, LLC*, 825 F.3d 1341 , 1349 (Fed. Cir. 2016) (quoting *Phillips*, 415 F.3d at 1317), *rev'd and remanded on other grounds*, U.S. , 138 S. Ct. 1348 (2018).

Tzumi asserts that Therabody's arguments distinguishing prior art during prosecution meet the standard for prosecution disclaimer, but even if they do not, that they nonetheless support Tzumi's claim construction by showing Therabody and the examiner's understanding of the claim terms at issue. (Def. Mem. at 13; Def.

Reply at 5-6.) Not so. While the cited prosecution history shows that Therabody disclaimed devices with a single handle, it does not clearly and unmistakably define the length of the claimed devices' handles, the size of the hand that must be accommodated, the firmness and comfort of the grip, or the number of fingers needed to "grasp" each of the three claimed handles in the asserted claims necessary to constitute a disclaimer of claim scope outside of Tzumi's proposed construction. The relevant prosecution history focuses on four prior art references — Pepe, which is discussed first below, and Rix, Oberheim, and Marte, which are then discussed together.

i. Pepe (U.S. Patent Pub No. 2017/0304145)

In the office action dated September 22, 2020 from prosecution of the '565 Patent, the examiner rejected claims 1 and 4-5 as being anticipated by Pepe. The examiner stated that Pepe disclosed a device that included, inter alia, "a housing 11 including first, second, and third handle portions ... defining ... the first second and third axes such that a user can grasp any of the first, second, or third handle portions independently to use the percussive massage device." (Ex. L at 3.) The Pepe figures annotated by the examiner show the three portions of the device that the examiner considered the "handle portions":

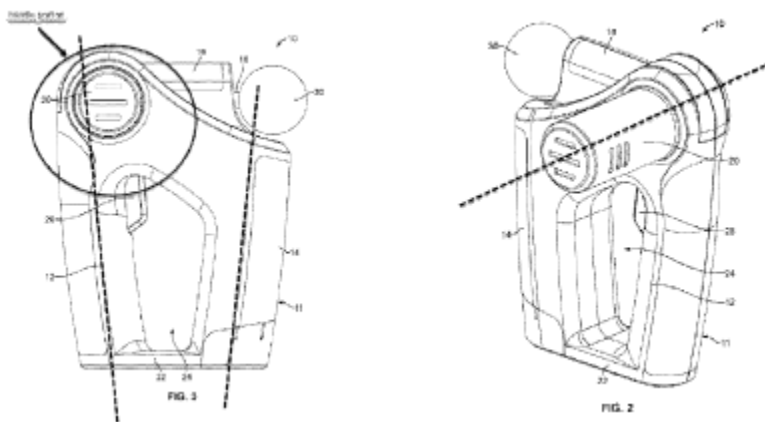

(Ex. L at 4-5.) In response, Therabody amended independent claim 1 to recite "wherein the first, second, and third axes are co-planar." (Ex. M. at 2, 13-14.) Because only two of the alleged three axes of the Pepe handle were co-planar, Therabody argued, claim 1 as amended defined over Pepe. (Ex. M at 13-14.) The examiner accepted that amendment, and the Notice of Allowability of the '565 Patent stated in relevant part:

[W]hen read in light of the limitations of the claimed percussive massage device/method of use, the prior art does not disclose, either alone or suggest in combination, a percussive massage device including a housing, electrical source, motor, switch, and push rod assembly, wherein the housing: a) includes first, second, and third generally straight handle portions that define a handle opening and first, second, and third axes, respectively, which are co-planar as set forth in independent claims 1 and 7 [issued claim 10]; b) the handle portions each defining interior edge and lengths which allow for a user to grasp with a hand such that three [*24] fingers extend through the handle opening and contact the respective handle portion interior edge as set forth in independent claims 2, 8, and 12 [issued claims 8, 14, and 16]...

(Ex. N at 3-4.)

Tzumi argues that because the examiner and Therabody did not define the transition between Pepe's two co-planar handles as a potential third co-planar handle portion, "the examiner and applicants left no doubt that [it] was too short to be a grasping handle." (Def. Mem. at 6.) Tzumi also asserts that the basis for allowability in part was that "the prior art does not disclose ... handle portions ... which are co-planar ... the handle portions each defining interior edge and lengths which allow for a user to grasp with a hand such that three fingers extend through" (Def. Mem. at 6 (quoting Ex. N at 3-4).) Having distinguished the prior art based on grasping handles of a certain length accommodating three fingers, the argument goes, Therabody cannot now argue that grasping means anything different. Tzumi's conclusion is not persuasive.

First, Tzumi's recitation of the examiner's reasons for allowance conflate the examiner's description of claims 1 and 7 (issued as claim 10) with his description of claims 2, 8, and 12 (issued as claims 8, 14, and 16). (See Ex. N at 3-4, quoted above; Pl. Mem. at 20.) The examiner distinguished claims 1 and 7 from the prior art on the basis of those claims having three generally straight, co-planar handle portions. Separately, the examiner distinguished claims 2, 8, and 12 from the prior art on the basis that it does not disclose a percussive massage device with "the handle portions each defining interior edge and lengths which allow for a user to grasp with a hand such that three fingers extend through the handle opening and contact the respective handle portion interior edge." (Ex. N at 4.) Nothing in the examiner's explanation warrants applying his justification for, and interpretation of, claims 2, 8, and 12 to claim 1. Notwithstanding Tzumi's use of ellipses, the examiner noted limitations related to the length of handles and number of fingers with which a handle can be grasped only in reference to claims 2, 8, and 12, which, as with the doctrine of claim differentiation discussed above, indicates that those limitations are **not** present in other claims, including asserted claim 1.

Second, Tzumi asks the Court to draw a conclusion that is entirely speculative. It is true that neither Therabody nor the examiner discussed the transition between the two co-planar handles of Pepe as a potential third handle. But why that is so is not clear from the prosecution history on which Tzumi relies. Tzumi asks the Court to speculate that i) the examiner did not identify the transition portion of Pepe's handles as a third grasping handle because it was too short to grasp; ii) Therabody accepted that interpretation by responding to the reason the examiner gave for rejection by adding the "co-planar" language; and iii) the examiner's allowance of the claims with the added "co-planar" limitation confirms that interpretation, because if the transition section had been long enough to **[*25]** be a handle, the co-planar limitation would not have distinguished the claimed invention from Pepe. Tzumi then asks the Court to conclude from this post-hoc explanation that Therabody has disclaimed devices other than those with three handles that are "of a length sufficient for a person with a large hand to firmly and comfortably grip each handle portion with at least three to four fingers extending through the opening."

The multiple speculative leaps of logic required by Tzumi's arguments, springing from the examiner's and Therabody's silence, are not solid ground on which to rest claim construction. See, e.g., *Prima Tek II, L.L.C. v. Polypap, S.A.R.L.*, 318 F.3d 1143, 1151 (Fed. Cir. 2003) ("drawing inferences of the meaning of claim terms from an examiner's silence is not a proper basis on which to construe a patent claim") (citing *DeMarini Sports, Inc. v. Worth, Inc.*, 239 F.3d 1314, 1326 (Fed. Cir. 2001)); *Dayco Products, Inc. v. Total Containment, Inc.*, 258 F.3d 1317, 1324 (Fed. Cir. 2001) (rejecting "speculative and convoluted reading of the claim language, the specification, and the prosecution history" because "[the Court's] objective is to interpret the claims from the perspective of one of ordinary skill in the art ... not from the viewpoint of counsel or expert witnesses retained

to offer creative arguments in infringement litigation") (internal citation omitted); *accord R+L Carriers, Inc. v. Qualcomm, Inc.*, 801 F.3d 1346 , 1350 (Fed. Cir. 2015) (disagreeing with defendant "read[ing] too much into" a claim term that was added for reasons unrelated to the construction of the disputed language and noting "[s]peculation about what [Plaintiff] was attempting to accomplish vis-à-vis [a cited prior art reference] does not change [the Court's] view"); *SanDisk Corp. v. Memorex Products, Inc.*, 415 F.3d 1278 , 1287 (Fed. Cir. 2005) ("An ambiguous disclaimer ... does not advance the patent's notice function or justify public reliance, and the court will not use it to limit a claim term's ordinary meaning"); *Generation II Orthotics Inc. v. Medical Technology Inc.*, 263 F.3d 1356 , 1365 (Fed. Cir. 2001) (declining defendant's argument "to construe the claims to avoid ensnaring the prior art").

ii. Rix (U.S. Patent No. 7 , 927 ,259), Oberheim (U.S. Patent Pub. No. 2009/0188119), and Marte (U.S. Patent No. 4 , 991 , 298)

Tzumi's other prosecution history arguments are also unpersuasive. All rely on the assertion that Therabody distinguished the prior art references "because the potential third handle was not long enough for comfortable and firm gripping with three to four fingers," and thereby disclaimed devices without such a third handle. (Def. Mem. at 13.) Tzumi argues that Therabody distinguished its device's handle portions from the following alleged handle portions (identified in the shaded areas) of the prior art references:

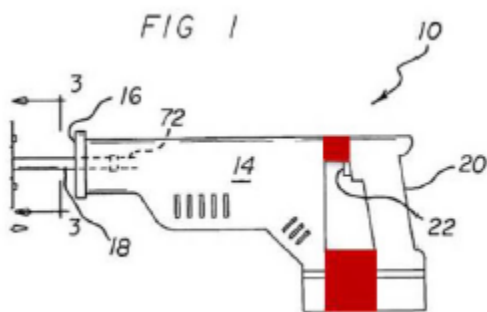

(Annotated Rix Fig. 1, Def. Mem. at 7.)

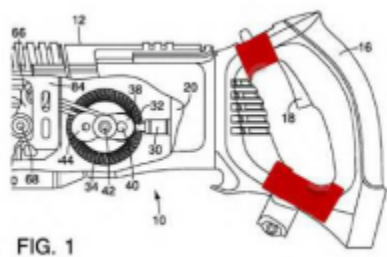

(Annotated Oberheim Fig. 1, Def. Mem. at 7.)



(Annotated Matre Fig. 1, Def. Mem. at 8.)

But again, Tzumi reads more into the prosecution history than was said. During prosecution of the '448 Patent, the examiner initially rejected, inter alia, claims 1 and 7 (issued as claim 6) as unpatentable as obvious over various combinations of prior art references. (Ex. P at 5-16.) The claims were amended to recite additional limitations, including that the first, second, [*26] and third axes of the handle opening cooperate to form a triangle and that the three handle portions are generally straight "such that a user can grasp any of the first, second, or third handle portions independently to use the percussive massage device." (Ex. I at 14-15.) These additional limitations were originally in claims 4 and 10, which were themselves rejected as obvious over Rix, Oberheim, and Matre. (Ex. I at 15.)

In response to the obviousness rejections based on those prior art references, Therabody argued that the examiner improperly "derived his conclusion of obviousness from the teaching in Applicant's specification that it is advantageous to be able to grasp separate handle portions using hindsight." (Ex. I at 15 (original emphasis omitted).) Therabody stated that:

the purpose of the first, second and third handle portions is to allow a user to grasp each of the three handle portions separately so that they can massage one or more body parts and/or use the percussive massage device in different orientations. None of Rix, Haas, Oberheim nor Matre teach, disclose or provid[e] separate handle portions, nor do they suggest that the alleged housings of the device can be grasped anywhere other than a single handle. More importantly, no motivation or reasoning is provided in Rix or any of the other references to modify Rix to include the claimed handle portion features ...

(Ex. I at 17(original emphasis omitted).)

Therabody distinguished Rix because the Rix device has only "a single handle." In support of that contention, the applicant noted that "Rix never mentions the components being handle portions nor provides any disclosure about grasping the handle portions." Similarly, Therabody noted that the Oberheim device includes only a single handle and does not "teach, disclose, or suggest grasping any portion of the device other than the rear handle." (Ex. I at 17.)

Concerning Matre, Therabody noted that it "teaches away from being used in a combination where the handle [] would be used to be grasped in different positions" because Matre requires the handle to remain in a horizontal position in order for the device to pivot. (Ex. I at 18.) While the single handle in Matre has three

sides, only the horizontal section is the actual gripping portion, again because the device claimed requires such in order to pivot during use. Because of that pivoting function, argued Therabody, "a person of ordinary skill in the art considering a reconfiguration of the handle of Oberheim, which has nothing to do with pivoting, would not look to Matre." (Ex. I at 18.)

Therabody notably did **not** argue that the alleged handle portions identified by the examiner were too short to be grasped, could not be grasped because a user could not grip the portion with three to four fingers, could not be gripped firmly and comfortably by a large hand, or the like. Therabody simply noted that the prior art only disclosed grasping a single handle and, additionally, that because Matre's three-sided handle was intended to allow the device to pivot while the user maintained a static horizontal [*27] grip, there would be no motivation to apply that handle shape to a device designed to be gripped and used in different positions without a pivot feature.

Tzumi emphasizes in reply that Therabody did mention the length of handles in its response to the examiner's rejections. (Def. Reply at 6.) But that discussion relates to new dependent claims 24 and 25 (now claims 17 and 18) which concern the length of the housing in relation to the length of the handle opening. The new claims read:

24. The percussive massage device of claim 7 wherein the housing defines a housing length, wherein at least a portion of the handle opening extends forwardly of half the housing length.

25. The percussive massage device of claim 7 wherein a transverse plane that bifurcates the housing extends through the handle opening.

(Ex. I at 8; *see also* '448 Patent claims 17-18.)

Therabody explained that "the Rix, Haas, Oberheim and Matre devices and housings thereof are all much longer overall than the handle openings and alleged handle portions" which "would make it awkward and unwieldy for a user to grasp the various alleged handle portions" in order to distinguish these new claims (which depend from an asserted "grasping" claim) over the prior art. (Ex. I at 20-23.) At most, this exchange appears to be a general disparagement of devices with handles that are much shorter than the device housing, or perhaps housings that are too long in relation to handles, at least as applied to the scope of dependent claims 16 and 17. But it is a far cry from defining the length of handles disclosed in other, independent claims, and farther still from defining the length as "sufficient for a person with a large hand to firmly and comfortably grip each handle portion with at least three to four fingers extending through the opening."

Again, the leaps from the prosecution history, to Tzumi's interpretation of it, then to Tzumi's proposed claim construction, are a bridge too far. *See Promos Technologies, Inc. v. Samsung Electronics Co.*, 809 F. App'x 825, 834 (Fed. Cir. 2020) (rejecting claim construction that required "several logical leaps" and a mischaracterization of the prosecution history); *accord Inverness Medical Switzerland GmbH v. Warner Lambert Co.*, 309 F.3d 1373, 1382 (Fed. Cir. 2002) (rejecting claim construction based on discussion of prior art in the prosecution history because the court was "not convinced that the prosecution history demonstrates that the patentee clearly was using the disputed language in a limited sense that would foreclose the broader dictionary definitions" encompassing a broader construction).

In short, the evidence presented by Tzumi — including the patent claims, their specifications, and their prosecution histories — does not indisputably establish Tzumi's highly specific construction of the grasping limitations.

C. The Court Should Defer Construing The "Grasping" Limitations Until Claim Construction Briefing Has Been Completed

Tzumi has not met its burden on summary judgment with respect to its proposed construction of the "grasping" limitations. The Court, however, declines to affirmatively [*28] adopt a claim construction for the disputed claim terms at this time. "While a trial court is obligated to interpret claims ... it need not do so simply because a party has made a dispositive motion. The timing of claim construction and the manner in which claims are construed vary from case to case." *Westvaco Corp. v. Viva Magnetics Ltd.*, No. 00-CV-9399, 2002 WL 31052870 , at *2 (S.D.N.Y. Sept. 13, 2002) (citing *Nutrinova Nutrition Specialties & Food Ingredients GmbH v. International Trade Commission*, 224 F.3d 1356 , 1360 (Fed. Cir. 2000)); accord *CytoLogix Corp. v. Ventana Medical Systems, Inc.*, 424 F.3d 1168 , 1172 (Fed. Cir. 2005) ("the district court has considerable latitude in determining when to resolve issues of claim construction"); *Financeware, Inc. v. UBS Financial Services*, No. 11-CV-5503, [2011 BL 315436], 2011 WL 6092311 , at *2 (S.D.N.Y. Dec. 7, 2011) ("scheduling a claim construction hearing, setting deadlines for discovery, and deciding when to determine the validity of a patent are all issues for the court to determine on a case by case basis").

While district courts are permitted to engage in "a rolling claim construction, in which the court revisits and alters its interpretation of the claim terms as its understanding of the technology evolves," *Jack Guttman, Inc. v. Kopykake Enterprises, Inc.*, 302 F.3d 1352 , 1361 (Fed. Cir. 2002), the Court believes that construing terms in fifteen claims on the current record and briefing, only to potentially revise its construction, will not serve to advance the case. Moreover, Therabody has not cross-moved for summary judgment, has not indicated who it considers to be a person of ordinary skill in the art (nor has Tzumi for that matter), and has not set forth what it considers the plain meaning of the grasping limitations except for a single piece of extrinsic evidence (i.e., a dictionary definition). Meanwhile, there is a jointly agreed and so-ordered schedule for determining claim construction.

The Court therefore recommends that claim construction occur after the issues have been fully briefed in accordance with the case management plan. See, e.g., *Halverson Wood Products, Inc. v. Classified Systems LLC*, No. CV 20-801 (JRT/LIB), [2021 BL 270888], 2021 WL 3036883 , at *4 (D. Minn. July 19, 2021) (denying summary judgment motion as premature where discovery on the understanding of a person of ordinary skill in the art had not occurred and the movant bypassed traditional claim construction); *DOK Solution LLC v. FKA Distributing Co.*, No. 8:14-CV-1910-T-30TBM, [2015 BL 100036], 2015 WL 1606339 , at *2 (M.D. Fla. Apr. 8, 2015) (where the defendant "merely provide[d] the Court with its own interpretation of the plain language of the claims," and claim construction discovery was ongoing, "the Court ha[d] insufficient information to construe the claims at issue" and so denied motion for summary judgment of noninfringement as premature); *Intellect Wireless, Inc. v. T-Mobile USA, Inc.*, 735 F. Supp. 2d 928 , 933 (N.D. Ill. 2010) (where the parties dispute claim construction and "neither a straightforward reading of the claims nor a review of the record now before the court conclusively establishes the meaning of the [operative] phrase, ... [thus] claim construction is necessary, and summary judgment is improper").

Because the Court recommends rejecting Tzumi's claim construction and deferring [*29] construction of the grasping limitations until the record is sufficiently developed, it does not reach the parties' arguments regarding literal infringement and infringement by the doctrine of equivalents.

CONCLUSION

For the foregoing reasons, I recommend Tzumi's motion be DENIED. To the extent not discussed herein, the Court has considered all of Tzumi's arguments and determined them to be without merit.

DEADLINE FOR FILING OBJECTIONS

Pursuant to 28 U.S.C. § 636(b)(1) and Rules 72 , 6(a) , and 6(d) of the Federal Rules of Civil Procedure , the parties shall have fourteen (14) days to file written objections to this Report and Recommendation. Such objections shall be filed with the Clerk of the Court, with extra copies delivered to the Chambers of the Honorable Paul G. Gardephe, United States Courthouse, 40 Foley Square, New York, New York 10007, and to the Chambers of the undersigned, at United States Courthouse, 500 Pearl Street, New York, New York 10007.

Failure to file timely objections will result in a waiver of the right to object and will preclude appellate review.

Respectfully submitted,

/s/ Robert W. Lehrburger

ROBERT W. LEHRBURGER

UNITED STATES MAGISTRATE JUDGE

Dated: November 28, 2022

New York, New York

fn

1

The facts are drawn from the parties' statements of material fact filed pursuant to Local Rule 56.1 and the exhibits submitted therewith. Exhibits A-T are attached to the Declaration of Scott D. Stimpson in Support of Defendant's Motion for Partial Summary Judgment of Non-Infringement at Dkts. 68-1 and 68-2. Exhibits U-GG are attached to the Declaration of Cameron W. Westin in Support of Therabody's Opposition to Defendants' Motion for Partial Summary Judgment at Dkt. 71-1.

fn

2

Tzumi filed the instant motion before Therabody served its Disclosure of Asserted Claims and Infringement Contentions, but Therabody did provide Tzumi in advance with a list of claims it intended to assert relevant

to this motion. Therabody's list inadvertently omitted claim 16 of U.S. Patent No. 10 , 857 ,064 and claims 8, 14 and 16 of U.S. Patent No. 10 , 918 ,565. While Tzumi's opening papers omitted discussion of these claims, it contends that the arguments therein are equally applicable to the "grasping limitations" in these additional claims. (Dkt. 74 ¶ 4.)

fn

3

"Pl. 56.1 Statement" refers to Therabody, Inc.'s Response to Defendant Tzumi Electronics LLC's Statement of [Purported] Undisputed Material Facts in Support of its Motion for Partial Summary Judgment of Non-Infringement at Dkt. 71.

fn

4

"Def. 56.1 Statement" refers to Tzumi's Statement of Material Facts of Defendant Tzumi Electronics LLC in Support of Motion for Partial Summary Judgment at Dkt. 68.

fn

5

"Def. Mem." refers to Tzumi's Memorandum of Law in Support of Defendant's Motion for Partial Summary Judgment of Non-Infringement at Dkt. 69.

fn

6

The inventors of each patent discussed herein assigned the patent to Theragun, Inc., which changed its name to Therabody, Inc. as of October 1, 2021. (Dkt. 53 at 1, n.1.)

fn

7

Claim language added by the amendment is bolded and underlined; language removed is struck through and bracketed.

fn

8

Amended claim 1 of the '565 Patent reads:

A percussive massage device comprising:

a housing, wherein the housing includes first, second and third handle portions that cooperate to at least partially define a handle opening, wherein the first handle portion defines a first axis, the second handle portion defines a second axis and the third handle portion defines a third axis, ***wherein the first, second and third axes are coplanar***, wherein the first handle portion is generally straight, wherein the second handle portion is generally

straight, and wherein the third handle portion is generally straight, such that a user can grasp any of the first, second or third handle portions independently to use the percussive massage device,

an electrical source,

a motor positioned in the housing,

a switch for activating the motor, and

a push rod assembly operatively connected to the motor and configured to reciprocate in response to activation of the motor.

(Ex. M at 2.)

fn
9

The Court takes judicial notice of prosecution history documents not filed as exhibits. *See Uniloc USA, Inc. v. ADP, LLC*, 772 F. App'x 890 , 898 n. 3 (Fed. Cir. 2019) (because "[t]he prosecution history is part of the intrinsic record of the patent and is a 'matter[] of public record' ... [i]t is thus subject to judicial notice") (quoting *Data Engine Technologies LLC. v. Google LLC*, 906 F.3d 999 , 1008 n.2 (Fed. Cir. 2018)).

fn
10

"Pl. Mem." refers to Therabody, Inc.'s Memorandum of Law in Opposition to Defendants' Motion for Partial Summary Judgment of Non-Infringement at Dkt. 70.

fn
11

The full subsection of Rule 56(d) provides:

(d) When Facts Are Unavailable to the Nonmovant. If a nonmovant shows by affidavit or declaration that, for specified reasons, it cannot present facts essential to justify its opposition, the court may:

- (1) defer considering the motion or deny it;
- (2) allow time to obtain affidavits or declarations or to take discovery; or
- (3) issue any other appropriate order.

Fed. R. Civ. P. 56 .

fn
12

"Def. Reply" refers to Tzumi's Reply Memorandum of Law in Further Support of Defendant's Motion for Partial Summary Judgment of Non-Infringement at Dkt. 72.

fn

13

The cases cited by Tzumi are inapt. In *Vizio, Inc. v. International Trade Commission*, 605 F.3d 1330 (Fed. Cir. 2010), the Federal Circuit rejected the appellant's "cryptic" claim differentiation argument because it incorrectly assumed that the limitation defined by the construction of the independent claim was present in the dependent claim, not because the dependent claim also added other, unrelated limitations. *Id.* at 1337 (rejecting claim differentiation argument because "[a]ppellants assume that the PCR value and the PCR_PID are the same. However, the Commission points out that the PCR value (referenced in claim 2) and the PCR_PID [construed as required in independent claim 1] are not the same"). And, unlike in *Andersen Corp. v. Fiber Composites, LLC*, 474 F.3d 1361, 1370 (Fed. Cir. 2007), Tzumi's construction would not only result in "overlap" but in a construction that would render the dependent claims inconsistent with, and broader than, the independent claims.

fn

14

Other portions of the specification reveal that, had the patentee wanted to clearly limit claim scope in the specification, it could have. For example, when describing the amplitude and frequency of the claimed device's output, the specification states:

It will be appreciated that the device operates most effectively within the combined frequency and amplitude ranges. When developing the invention, the inventor determined that if the frequency and amplitude are above the ranges set forth above the device can cause pain and below the ranges the device is ineffective and does not provide effective therapeutic relief or massage. Only when the device operates within the disclosed combination of frequency and amplitude ranges does it provide efficient and therapeutically beneficial treatment to the muscles targeted by the device.

('448 Patent at 10:27-37.) In this passage, the patentee states that the described frequency and amplitude ranges make the device operate "most effectively" and disparages devices that operate outside of that range as either causing pain or as ineffective. No similar language accompanies the descriptions of "grasping" cited by Tzumi. See *Pulse Electronics, Inc. v. U.D. Electronic Corp.*, 860 F. App'x 735, 738 (Fed. Cir. 2021) (rejecting patentee's argument importing limitations from an embodiment into the claim and noting that the patent-in-suit "demonstrates ... that [the patentee] knew how to restrict angles to 90 degrees when it wanted to—and did not so limit the "effectively curved portion" too).

fn

15

Tzumi does not explain how "grasp" can be clearly defined by language that itself includes the term to be defined.