

Pagination

* U.S.P.Q.2d

** BL

Majority Opinion >

UNITED STATES DISTRICT COURT FOR THE
EASTERN DISTRICT OF NEW YORK

SHAF INTERNATIONAL, INC., Plaintiff, - against
- FIRST MANUFACTURING CO., INC.,
Defendant.

20-CV-1242 (PKC) (LGD)

September 26, 2024, Filed

September 26, 2024, Decided

For Shaf International, Inc., a New Jersey company, Plaintiff: John H. Choi, LEAD ATTORNEY, John H. Choi & Associates LLC, Ridgefield Park, NJ.

For First Manufacturing Co. Inc., a New York company, Defendant: Roger Sherman Thompson, LEAD ATTORNEY, Law Offices of Roger S. Thompson, New York, NY; Sanjay Chaubey, Law Offices of Sanjay Chaubey, Pleasantville, NY.

For First Manufacturing Co. Inc., a New York company, Counter Claimant: Roger Sherman Thompson, LEAD ATTORNEY, Law Offices of

Roger S. Thompson, New York, NY.

For Shaf International, Inc., a New Jersey company, Counter Defendant: John H. Choi, LEAD ATTORNEY, John H. Choi & Associates LLC, Ridgefield Park, NJ.

Pamela K. Chen, United States District Judge.

Pamela K. Chen

**MEMORANDUM
& ORDER**

PAMELA K. CHEN, United States District Judge:

Plaintiff Shaf International, Inc. ("Plaintiff") has brought this action against Defendant First Manufacturing Co., Inc. ("Defendant" or "FMC") for selling garments in violation of Plaintiffs **U.S. Patent No. 10**, 433,598 titled "Liner Access Means," issued on October 8, 2019 (the "Patent"). The Court previously ruled on the meaning of two disputed terms used in the Patent. (*See* Claim Constr. Mem. & Order, Dkt. 71); *see also* *Shaf Int'l, Inc. v. First Mfg. Co. Inc.*, No. 20-CV-1242 (PKC) (ST), 2022 U.S. Dist. LEXIS 125700, 2022 WL 2791999 (E.D.N.Y. July 15, 2022). Now before the Court are the parties' cross-motions for summary judgment on Patent validity and infringement. During summary judgment briefing, the parties also briefed a dispute as to the construction of the term "coupled." For the reasons explained below, the Court adopts the construction of the term "coupled" as meaning "directly attached." Additionally, for the reasons explained below, the Court denies Defendant's motion for summary

judgment on invalidity, grants Plaintiffs cross-motion for summary judgment on that issue and finds, as a matter of law, that the Patent is valid. The Court grants Defendant's motion for summary judgment on noninfringement as to Patent claims 1 through 10 only, and denies the cross-motions for summary judgment on infringement as to Patent claims 11 through 18.

BACKGROUND

I. Factual Background

A. Plaintiff's Patent

Plaintiff designs, manufactures, and sells leather goods, including jackets and vests. (See Decl. of Mohammad Maqbool ("Maqbool Decl."), Dkt. 88-3 ¶ 7; see also Complaint ("Compl."), Dkt. 1 ¶ 14.) Plaintiff is the owner of the Patent, titled "Liner Access Means" and issued on October 8, 2019, by the U.S. Patent and Trademark Office (the "PTO").¹ (Maqbool Decl., Dkt. 88-3 ¶ 2; see also Compl., Dkt. 1 ¶ 11.) The invention protected by the Patent is a lined garment; the liner has an opening, such as a zipper, that makes it easy to access the garment's fabric (or the "outer layer") to decorate the garment with, for example, embroidery, without detaching the liner from the outer layer. (See Patent, Dkt. 88-5 at ECF₂ 9.) An example of the invention is pictured on the following page:

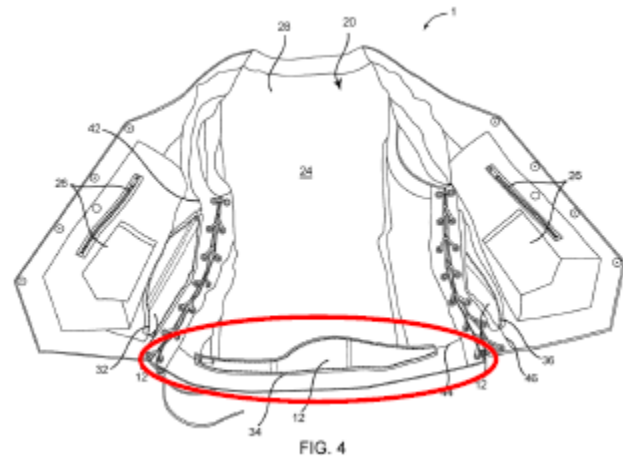

(Figure 4, *id.* at ECF 6 (emphasis in red on the opening supplied by the Court).) The Patent contains 18 [*2] [**2] claims in total, with three independent and fifteen dependent claims. (*Id.* at ECF 10-11); see also Discussion *infra* Section II.B, (including the text of the three independent claims).

B. Defendant's Patent Applications

Defendant also manufactures and sells leather goods including jackets and vests. (Answer, Dkt. 28 ¶ 15.) One of Defendant's "line[s] of products . . . include[s] a partially removable liner on a back panel of a jacket or vest" for easy access to the garment. (Def. 's Resp. to Pl.'s 56.1₃ Statement ("56.1 Resp."), Dkt. 90 ¶ 6.) On May 18, 2017, several months after Plaintiff filed its provisional patent application, Defendant filed **patent application No. 15/599,014** ("014 Application") titled "Lining System for Articles of Clothing," which sought to protect a similar invention to that contained in the Patent. (U.S. **Patent Application No. 15/599,014** , Dkt. 1-2 at ECF 1.) Defendant's '014 Application related to "[a] lining system for articles of clothing" with "easy access to inward facing surfaces of outer panel portions of the article of clothing," as pictured on the

following page. (*Id.*)

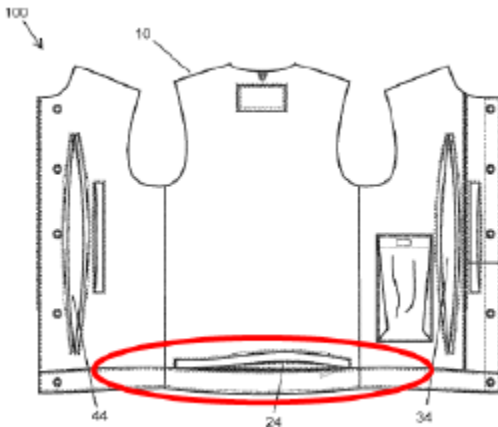

(*Id.* (emphasis in red on the opening supplied by the Court).) On October 18, 2019, the PTO issued a notice of abandonment with respect to Defendant's '014 Application.⁴ (USPTO Docket for [Patent Application #15/599,014](#), Dkt. 25 at ECF 2.)

Defendant later applied for, and received, a different but related patent. ([U.S. Patent No. 10](#), 918,147, Dkt. 98-9 at 1-5.) That patent is also for a "lining system for articles of clothing," however, that "system includes a plurality of detachable fasteners," as opposed to only one. (*Id.* at 1.) Defendant also later applied for an additional patent on its already-patented lining system with multiple detachable fasteners. (See *U.S. Patent App. No. 17/248,921*, Dkt. 98-10 at 1.)

C. Prior Art

Numerous patents have been issued for prior art that resembles the Patent. Many of these pre-existing patents were before the Patent Examiner at the time the Patent was under consideration. (See Patent, Dkt. 88-5 at ECF 1-2 (citing more than a dozen documents relating to

pre-existing U.S. patents).) In addition, Defendant has identified several additional relevant patents not considered by the Patent Examiner that existed at the time of the Patent's issuance: the Carey Patent (Canadian Patent App. No. 2,244,701, Dkt. 97-13), the Adams Patent (AU Patent App. No. 2013100214 A4, Dkt. 97-14), and the Fitch Patent ([U.S. Patent No. 2](#), 594,259, Dkt. 97-15), each of which is described in more detail below, (see Def.'s Mem. Supp. Summ. J. of Invalidity ("Def.'s Invalidity Br."), Dkt. 97-1 at 6-11). In addition, Defendant points to another piece of unpatented prior art that was not before the Patent Examiner: a vest known as the Black Brand "Axe" vest sold by a company called Tucker Rocky beginning in early 2016. (*Id.* at 11-17.)

1. The Carey Patent

The Carey Patent is a Canadian patent dating to 1999. (Canadian Patent App. No. 2,244,701, Dkt. 97-13 at ECF 1; see *also* Def.'s Invalidity Br. at 6.) The Carey Patent covers "[a] jacket and a method of embroidering [it.] The jacket has an inner lining with an access opening with a closure" that permits "embroidering an outer shell of the jacket through the access opening." (Canadian Patent App. No. 2,244,701, Dkt. 97-13 at [*3] [**3] ECF 2.) The Carey Patent further explains that while "more than one access opening . . . may be used to enable access to more than one position on [the] interior surface [] of [the] outer shell [of the jacket], as [the] lining [] does not have sufficient strength in all positions to support closure." (*Id.* at 3.) It goes on: "It is for this reason that the preferred position [for the opening] is extending substantially parallel to one of the overlapping [outer] edges" of the jacket. (*Id.* at 3.) The Carey Patent includes the following illustration of the invention, among others:

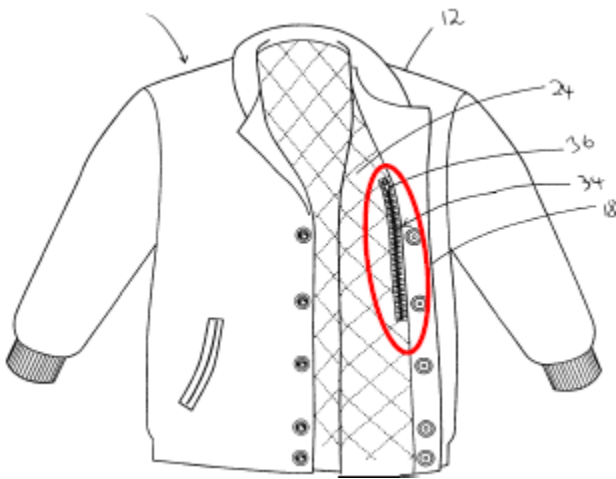

(*Id.* at ECF 11 (emphasis in red on the opening supplied by the Court).)

2. The Adams Patent

The Adams Patent is an Australian patent dating to 2013. (AU Patent App. No. 2013100214 A4, Dkt. 97-14 at ECF 1.) The Adams Patent describes "[a]n item of clothing," which is "[p]referably . . . a motorbike jacket or vest," "including a panel with lining fitted over a rear side of the panel, an opening in the lining and a closure device to selectively provide entry through the opening for clear access to a rear of the panel for the purpose of fixing a badge onto the front of the panel."⁵ (*Id.* at ECF 2, 5.) The Adams Patent further explains that the preferred "closure device is a zipper" and "[p]referably, the zipper extends between a bottom and top of the panel, adjacent snap fasteners that are fixed into an edge of the panel" and are "hidden inside a front panel of the item of clothing." (*Id.* at ECF 5.) A diagram of the invention contemplated by the Adams Patent is pictured below:

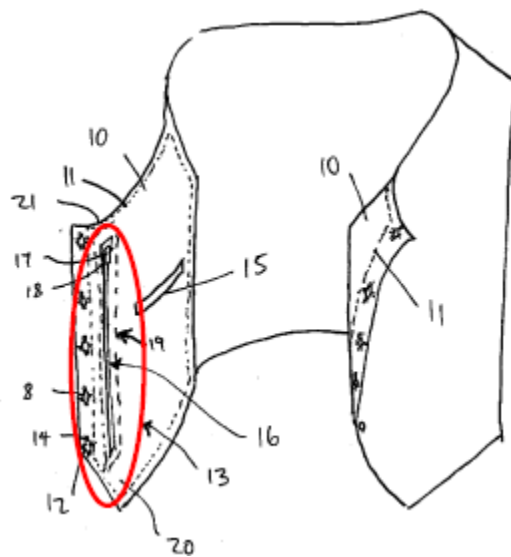

(*Id.* at ECF 3 (emphasis in red on the opening supplied by the Court).)

3. The Fitch Patent

The Fitch Patent is a U.S. patent first filed in 1950. ([U.S. Patent No. 2,594,259](#), Dkt. 97-15 at ECF 1.) The Fitch Patent "relates to a . . . garment construction including a removable lining member capable of serving as a separate garment." (*Id.* at ECF 2.) A fastening mechanism allows the lining garment to attach to the shell garment. (*Id.*) A diagram of the garment(s) described in the Fitch Patent is on the following page:

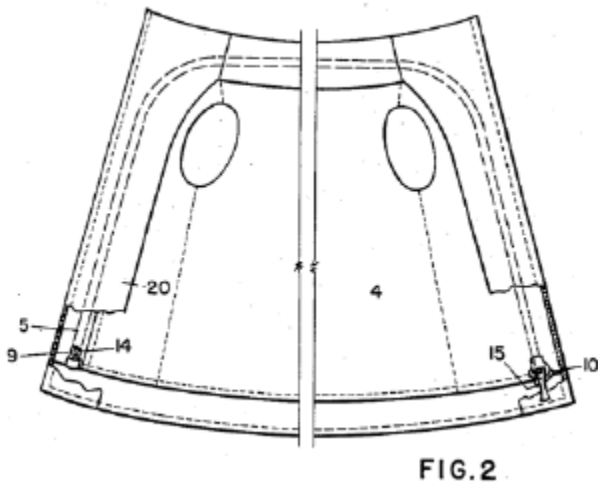

(*Id.* at ECF 1.)

4. Black Brand "Axe" Vest

In or around February 2016, a brand of motorcycle vests known as "Black Brand" vests were sold to a company called Tucker Rocky by a supplier named ProTech. (Def.'s R. 56.1 on Invalidity, Dkt. 97-5 I 89-90.) Tucker Rocky began advertising the Black Brand vests for sale sometime in early 2016. (See, e.g., Black Brand Motorcycle Clothing Spring 2016 Catalog, Dkt. 97-21; cf. Kelly Dep., Dkt. 97-16 at 14:14-21 (explaining that the Black Brand vests were developed between June 2015 and February 2016).) One of the vests sold as a part of the Black Brand line was called the "Axe" vest. (Def.'s R. 56.1 on Invalidity, Dkt. 97-5 ¶¶ 92-93.) The Axe vest was advertised as having "a full zippered inner liner for attaching patches." (Black Brand Motorcycle Clothing Fall 2016 Catalog, Dkt. 97-22 at ECF 6; see also Black Brand Motorcycle Clothing Spring 2016 Catalog, Dkt. 97-21 at ECF 6 (describing the Axe vest as having an "[i]nside liner zipper for easy patch installation").) As demonstrated in the image below, the Axe vest has a flap or compartment

on the back of the vest with a zipper closure.



(Figure 3, Def.'s R. 56.1 on Invalidity, Dkt. 97-5 ¶ 100 (emphasis in yellow supplied by Defendant).)[*4] [**4]

D. Plaintiff's Patented Products

Plaintiffs sells a line of vests under the "Milwaukee Leather" brand that include the feature protected by the Patent. (Maqbool Decl., Dkt. 88-3 ¶ 7; see also Exhs. 14-16 to Maqbool Decl., Dkt. 88-3 at ECF 18-20 (images of a Milwaukee Leather vest).) Mohammed Maqbool, Shafts Chief Executive Officer and creator of the invention protected by the Patent, testified that he had known about the difficulty seamstresses have attaching patches to the back of leather jackets for some time, but that he made it a "priority" to solve this problem beginning in March 2016. (Maqbool Dep., Dkt. 98-3 at 105:5-106:25.)

E. The Accused Products

The Accused Products are a line of motorcycle vests sold by Defendants that have "easy access panels" that permit access to the inner portion of the leather on the back panel of the vest. (See Screenshots of Accused Product Internet Listings, Dkt. 1-6; Maqbool Decl., Dkt 88-3 ¶¶ 8-15 (describing one such vest); Exhs. 1-13 of the Maqbool Decl., *id.* at ECF 5-17 (images of the Accused Product described in the Maqbool Decl.).) Defendant admits that at least one of the Accused Products contains a liner positioned on the back portion of the garment that has a "fastener coupled to the liner" which forms a space "between the liner and the back portion of the garment" when opened. (Answers to Requests to Admit, Dkt. 88-13 ¶¶ 22-26.) One of the Accused Products is pictured below.



(Exh. 16 to Maqbool Decl., Dkt. 88-3 at ECF 20 (emphasis in red on the opening supplied by the Court).)

II. Procedural History

In November 2017, Plaintiff sent a letter to Defendant advising Defendant of Plaintiff's Patent application and that Plaintiff would exercise legal

rights available to it if and when the Patent issued. (See 11/6/17 Ltr. to FMC, Dkt. 1-4.) In November 2019, after obtaining the Patent, Plaintiff sent another letter to Defendant asserting that Defendant was infringing the Patent and demanding information regarding infringing products in order to resolve the dispute without court action. (See 11/26/19 Ltr. to FMC, Dkt. 1-5.) Defendant did not respond to Plaintiff's letters. (Answer, Dkt. 28 ¶ 22.)

On March 6, 2020, Plaintiff filed the Complaint in this action asserting infringement of the Patent and false marking by Defendant, and seeking injunctive and monetary relief. (Compl., Dkt. 1 ¶¶ 24-34.) On May 27, 2020, the Clerk of Court entered a default against Defendant for failure to appear and/or defend the action. (Entry of Default, Dkt. 9.) On June 11, 2020, Defendant's counsel filed a notice of appearance and a letter stating intent to file a motion to vacate the certificate of default and to stay default judgment-related discovery. (6/11/20 Ltr. from FMC, Dkt. 12.) The entry of default was ultimately vacated. (See 8/18/2020 Min. Order.) Defendant filed an answer on August 28, 2020, raising affirmative defenses and counterclaims against Plaintiff, and asserting, among other things, that the Patent is invalid and/or unenforceable. (See, *e.g.*, Answer, Dkt. 28 ¶ 45.) Plaintiff answered the counterclaims on September 18, 2020. (Pl.'s Answer, Dkt. 33.)

In 2021, the parties submitted a list of nine terms in the Patent with disputed [*5] [**5] meanings. (See Disputed Terms Chart, Dkt. 51-1.) The parties briefed several claim construction issues. (Dkts. 52, 54, 56.) During the briefing process, the parties narrowed the list of disputed terms to two, and this Court ultimately ruled on the meaning of those two terms: "back portion" and

"substantially outermost extent." (See Claim Construction Mem. & Order, Dkt. 71); see also *Shaf Int'l, Inc.*, 2022 U.S. Dist. LEXIS 125700 , 2022 WL 2791999 . Specifically, the Court held that "back portion" means the "portion of the outer layer that covers the entire back panel of the garment," (Claim Construction Mem. & Order, Dkt. 71 at 18), and "substantially outermost extent" means as "at or near the boundaries of the portion of the outer layer that covers the entire back panel of the garment," (*id.* at 25).

After the Court determined the meaning of these key terms, the parties proceeded with discovery. (12/9/21 Scheduling Order.) The parties completed discovery in June 2023. (6/6/23 Min. Entry.) They then filed cross-motions for summary judgment on infringement, (see Pl.'s Mem. Supp. Summ. J. on Infringement, Dkt. 88; Def.'s Mem. Opp'n Summ. J. on Infringement ("Def.'s Infringement Resp. Br."), Dkt. 89), and on Patent validity (see Def.'s Invalidity Br., Dkt. 97-1; Pl.'s Mem. Supp. Summ. J. of Validity ("Pl.'s Validity Br."), Dkt. 98). At the same time, both parties filed motions to seal related to portions of their respective summary judgment briefing and/or exhibits. (See Pl.'s Mot. to Seal, Dkt. 92; Def.'s Mot. to Seal, Dkt. 93; Pl.'s Supplemental Mot. to Seal, Dkt. 94.) After summary judgment briefing concluded, Defendant filed a letter motion, in which it argued that Plaintiff "for the first time introduced a definition of 'coupled' which was never before mentioned or relied upon." (Def.'s Ltr. Mot. to File Sur-Reply, Dkt. 95 at ECF 1.) Defendant requested leave to file a sur-reply "directed solely to the newly introduced definition of 'coupled.'" (*Id.* at ECF 3.) The Court granted Defendant's request and set a deadline for Defendant to do so. (11/21/2023 Dkt. Order.) Defendant twice

missed the Court-ordered deadline to file its requested sur-reply. (See 12/12/2023 Dkt. Order; 12/15/2023 Dkt. Order.) As such, the Court construes Defendant's letter motion seeking leave to file a sur-reply as the operative sur-reply. (See 12/15/2023 Dkt. Order.)

On June 12, 2024, the Court denied both parties' motions to seal, and ordered the parties to "file all outstanding summary judgment documents on the public docket." (Mem. & Order re: Mots. to Seal, Dkt. 96 at 6.) The parties did so. (See Dkts. 97-102.) The cross motions for summary judgment are now ripe for review.

LEGAL STANDARD

"When deciding issues in a patent case, a district court applies the law of the circuit in which it sits to nonpatent issues and the law of the Federal Circuit to issues of substantive patent law." *Revlon Consumer Prods. Corp. v. Estee Lauder Cos. Inc.*, No. 00-CV-5960 (RMB) (AJP), 2003 U.S. Dist. LEXIS 13004 , 2003 WL 21751833 , at *7 (S.D.N.Y. July 30, 2003) (citing *In re Cambridge Biotech Corp.*, [186 F.3d 1356](#) , [1368](#) (Fed. Cir. 1999)). "The standard for summary judgment in a patent case is the same as in any other case." *CA, Inc. v. Simple.com, Inc.*, [780 F. Supp. 2d 196](#) , [208](#) (E.D.N.Y. 2009) (citing *Desper Prods., Inc. v. QSound Labs, Inc.*, [157 F.3d 1325](#) , [1332](#) (Fed. Cir. 1998)). Summary judgment is appropriate where the submissions of the parties, taken together, "show[] that there **[*6] [**6]** is no genuine dispute as to any material fact and the movant is entitled to judgment as a matter of law." **Fed. R. Civ. P. 56(a)** ; see also *Anderson v. Liberty Lobby, Inc.*, [477 U.S. 242](#) , [251-52](#) , [106 S. Ct. 2505](#) , [91 L. Ed. 2d 202](#) (1986) (noting that the summary judgment

inquiry is "whether the evidence presents a sufficient disagreement to require submission to a jury or whether it is so one-sided that one party must prevail as a matter of law"). A dispute of fact is "genuine" if "the [record] evidence is such that a reasonable jury could return a verdict for the nonmoving party." *Anderson*, **477 U.S. at 248**.

The initial "burden of establishing the absence of any genuine issue of material fact" rests with the moving party. *Zalaski v. City of Bridgeport Police Dep't*, **613 F.3d 336**, **340** (2d Cir. 2010) (citing *Celotex Corp. v. Catrett*, **477 U.S. 317**, **322**, **106 S. Ct. 2548**, **91 L. Ed. 2d 265** (1986)). Once this burden is met, the burden shifts to the nonmoving party to put forward some evidence establishing the existence of a question of fact that must be resolved at trial. *Spinelli v. City of New York*, **579 F.3d 160**, **166-67** (2d Cir. 2009); *see also Celotex Corp.*, **477 U.S. at 322-23**. A mere "scintilla of evidence" in support of the nonmoving party is "insufficient; there must be evidence on which the jury could reasonably find for the [nonmovant]." *Hayut v. State Univ. of NY*, **352 F.3d 733**, **743** (2d Cir. 2003) (alteration in original) (quoting *Anderson*, **477 U.S. at 252**). In other words, "[t]he nonmoving party must come forward with specific facts showing that there is a genuine issue for trial." *Caldarola v. Calabrese*, **298 F.3d 156**, **160** (2d Cir. 2002) (emphasis omitted) (quoting *Matsushita Elec. Indus. Co. v. Zenith Radio Corp.*, **475 U.S. 574**, **586-87**, **106 S. Ct. 1348**, **89 L. Ed. 2d 538** (1986)). This holds true when analyzing cross-motions for summary judgment: "each party's motion must be examined on its own merits, and in each case all reasonable inferences must be drawn against the party whose motion is under consideration." *Morales v. Quintel Entertainment, Inc.*, **249 F.3d 115**, **121** (2d Cir. 2001).

In determining whether a genuine issue of material fact exists, the Court must resolve all ambiguities and draw all reasonable inferences against the moving party. *Major League Baseball Props., Inc. v. Salvino, Inc.*, **542 F.3d 290**, **309** (2d Cir. 2008). The Court also construes any disputed facts in the light most favorable to the nonmoving party. *See Adickes v. S.H. Kress & Co.*, **398 U.S. 144**, **158-59**, **90 S. Ct. 1598**, **26 L. Ed. 2d 142** (1970). However, "the mere existence of some alleged factual dispute between the parties will not defeat an otherwise properly supported motion for summary judgment." *Anderson*, **477 U.S. at 247-48** (emphasis omitted).

DISCUSSION

I. Claim Construction with Respect to "Coupled"

As explained in the background section, *supra*, the parties already briefed, and this Court already issued an Order regarding, several issues of claim construction. (See Claim Construction Mem. & Order, Dkt. 71); *see also Shaf Int'l, Inc.*, *2022 U.S. Dist. LEXIS 125700*, *2022 WL 2791999*. In the summary judgment briefing process, however, the parties indicated that an additional term—"coupled"—was disputed. (See *Pl.'s Infringement Reply Br.*, Dkt. 91 at 5-7; *Def.'s Ltr. Mot. to File Sur-Reply*, Dkt. 95 at ECF 1-3.) For the reasons explained below, the Court finds that the term "coupled" means "directly attached."

A. Legal Standard

"[T]he construction of a patent, including terms of

art within its claim, is exclusively within the province of the court." *Markman v. Westview Instruments, Inc.*, **517 U.S. 370**, **372**, **116 S. Ct. 1384**, **134 L. Ed. 2d 577** (1996). Thus, "when the parties present a fundamental dispute [*7] [**7] regarding the scope of a claim term, it is the court's duty to resolve it." *Eon Corp. IP Holdings v. Silver Spring Networks*, **815 F.3d 1314**, **1318** (Fed. Cir. 2016) (quotations omitted). Moreover, "[o]nly when a claim is properly understood can a determination be made whether the . . . the prior art . . . renders obvious the claimed invention." *Amazon.com, Inc. v. Barnesandnoble.com, Inc.*, **239 F.3d 1343**, **1351** (Fed. Cir. 2001). Similarly, where claim terms are disputed, claim construction is a prerequisite to conducting any infringement analysis. *David Netzer Consulting Eng'r LLC v. Shell Oil Co.*, **824 F.3d 989**, **993** (Fed. Cir. 2016) ("To determine infringement, a court first construes the scope and meaning of the asserted patent claims, and then compares the construed claims to the accused product[.]") Thus, claim construction is a threshold question that courts must reach before resolving validity or infringement motions.

The Court is "not bound by the parties' arguments as to claim construction." *Sony Corp. v. Iancu*, **924 F.3d 1235**, **1240** (Fed. Cir. 2019); see also *Exxon Chem. Pats., Inc. v. Lubrizol Corp.*, **64 F.3d 1553**, **1555** (Fed. Cir. 1995) ("[T]he trial judge has an independent obligation to determine the meaning of the claims, notwithstanding the views asserted by the adversary parties."). Instead, "claims terms are generally given their ordinary and customary meaning." *Eon*, **815 F.3d at 1320**. "There are only two exceptions to this general rule: 1) when a patentee sets out a definition and acts as his own lexicographer, or 2) when the patentee disavows the full scope of a claim term either in

the specification or during prosecution." *Thorner v. Sony Comput. Ent. Am. LLC*, **669 F.3d 1362**, **1365** (Fed. Cir. 2012). And, "[w]here the specification makes clear that the invention does not include a particular feature, that feature is deemed to be outside the reach of the claims of the patent, even though the language of the claims, read without reference to the specification, might be considered broad enough to encompass the feature in question." *Id.* at 1366; see also *Brookhill-Wilk 1, LLC v. Intuitive Surgical, Inc.*, **334 F.3d 1294**, **1298** (Fed. Cir. 2003) ("The written description must be examined in every case, because it is relevant not only to aid in the claim construction analysis, but also to determine if the presumption of ordinary and customary meaning is rebutted.").

"In some cases, the ordinary meaning of claim language as understood by a person of skill in the art may be readily apparent even to lay judges, and claim construction in such cases involves little more than the application of the widely accepted meaning of commonly understood words." *Phillips v. AWH Corp.*, **415 F.3d 1303**, **1314** (Fed. Cir. 2005) (en banc); see also *Active Video Networks, Inc. v. Verizon Commc'ns, Inc.*, **694 F.3d 1312**, **1326** (Fed. Cir. 2012) ("The district court did not err in concluding that these terms have plain meanings that do not require additional construction."). However, "[a] determination that a claim term 'needs no construction' or has the 'plain and ordinary meaning' may be inadequate when a term has more than one 'ordinary' meaning or when reliance on a term's 'ordinary' meaning does not resolve the parties' dispute." *02 Micro Int'l Ltd. v. Beyond Innovation Tech. Co., Ltd.*, **521 F.3d 1351**, **1361** (Fed. Cir. 2008).

"In determining the proper construction of a

claim, the court has numerous sources that [*8] [**8] it may properly utilize for guidance." *Vitronics Corp. v. Conceptronic, Inc.*, 90 F.3d 1576 , 1582 (Fed. Cir. 1996). Although these sources include both intrinsic and extrinsic evidence, courts must first look to all available intrinsic evidence, "i.e., the patent itself, including the claims, the specification and, if in evidence, the prosecution history," before considering any extrinsic evidence. *Id.* (citing *Markman v. Westview Instruments, Inc.*, 52 F.3d 967 , 979 (Fed. Cir. 1995), *aff'd*, 517 U.S. 370 , 116 S. Ct. 1384 , 134 L. Ed. 2d 577 (1996)). "In most situations, an analysis of the intrinsic evidence alone will resolve any ambiguity in a disputed claim term. In such circumstances, it is improper to rely on extrinsic evidence." *Id.* at 1583. At the same time, "[a]lthough . . . dictionaries fall within the category of extrinsic evidence, as they do not form a part of an integrated patent document," the Court "may . . . rely on dictionary definitions when construing claim terms, so long as the dictionary definition does not contradict any definition found in or ascertained by a reading of the patent documents." *Id.* at 1583 n.6.

B. The Claim

Term at Issue:

"Coupled"

The Patent contains three independent claims-1, 11, and 16.⁶ Claim 1 of the Patent discloses:

A garment or accessory, comprising:

an outer layer having a back portion with an inner surface and an outer surface;

a liner positioned on the outer layer

back portion, the liner having a first perimeter being a substantially outermost extent of the back portion, a portion of said first perimeter **coupled** to said inner surface, the liner and the outer layer at least partially **coupled** together permanently along the first perimeter;

a fastener, having a first member **coupled** to said inner surface and a second member **coupled** to said liner at an uncoupled portion of said first perimeter, with the fastener having a closed state when the first member engages the second member, and the fastener having an open state when the first member is disengaged from the second member;

a space formed between said liner and said inner surface within the first perimeter, wherein the space is completely enclosed when the fastener is in the closed state; and

an opening formed on the first perimeter when the fastener is in the open state, wherein the opening is positioned on the uncoupled portion between the liner and the outer layer;

wherein said space is accessible through said uncoupled portion.

(Patent col. 4-5 11. 57-67, 1-15, Dkt. 88-5 at ECF 10-11 (emphasis on disputed term added).)

(emphasis on disputed term added.)

Claim 11 of the Patent discloses:

A garment or accessory, comprising:

an outer layer having a back portion with an inner surface and an outer surface;

a liner positioned on the outer layer back portion, the liner having a first perimeter being a substantially outermost extent of the back portion, and an opening formed on the first perimeter, the liner being at least partially **coupled** to the outer layer permanently along the first perimeter, wherein the opening is positioned on an uncoupled portion between the liner and the outer layer, and with a space formed between the outer layer and the liner within the first perimeter, the space being [*9] [**9] accessible through the opening; and

a fastener having a first member and a second member, with the fastener having a closed state when the first member engages the second member, and the fastener having an open state when the first member is disengaged from the second member, with the fastener operably **coupled** to the liner such that the opening is closable in the closed state of the fastener to completely enclose the space, and the opening is open in the open state of the fastener.

(Patent col. 5-6 11. 39-49, 1-11, *id.* at ECF 11

Claim 16 of the Patent discloses:

A garment or accessory, comprising:

an outer layer having a back portion with a first inner surface and an opposing first outer surface;

an inner layer having a second inner surface, an opposing second outer surface, and a first perimeter being a substantially outermost extent of the back portion, the inner and outer layers at least partially **coupled** together permanently along the first perimeter, a space formed between the inner and outer layers within the first perimeter;

a fastener having a first member and a second member, with the fastener having a closed state when the first member engages the second member, with the space being completely enclosed when the fastener is in the closed state, and the fastener having an open state when the first member is disengaged from the second member; and

an opening formed on the first perimeter when the fastener is in the open state, wherein the opening is positioned on an uncoupled portion between the inner and outer layers.

(Patent col. 6 11. 23-43, *id.* at ECF 11 (emphasis on disputed term added).)

The Court construes the term "coupled," the meaning of which is still disputed by the parties.

C. Analysis

Plaintiff argues that "[t]he plain and ordinary meaning of 'coupled to,' does not limit the claim language to a direct attachment." (Pl.'s Infringement Reply Br., Dkt. 91 at 5.) In support of this contention, Plaintiff cites a dictionary definition, (see *Coupled*, Vocabulary.com, Dkt. 91-2 at ECF 4), and several cases, (see Pl.'s Infringement Reply Br., Dkt. 91 at 6 (collecting cases)). In response, Defendant argues that "coupled" should *not* be defined to include "joinder *via* an indirect link " (Def.'s Ltr. Mot. to File Sur-Reply, Dkt. 95 at ECF 1.) Instead, Defendant implies that "coupled" should be construed to mean "directly attached." (See *id.* at ECF 2.) In support of its argument, Defendant points out that in the Patent, "the inventor only refers to items which are directly attached to one another as being 'coupled[.]'" (*Id.*) When items are indirectly attached, Defendant argues, "the inventor of the [] Patent uses the term 'operably coupled' (see, e.g., claim 11)[.]" (*Id.*) The term "operably coupled" is thus "distinct from ' coupled[.]'" (*Id.*) Defendant further explains that the Federal Circuit has cautioned against "over-reliance on a single dictionary" as "potentially misleading," (*id.* (citing *Sun Pharm. Indus. v. Eli Lilly & Co.*, **611 F.3d 1381** , **1388** (Fed. Cir. 2010))), and correctly notes that Plaintiff "relies on the **second** of two definitions of 'coupled' found in a general-purpose dictionary to argue that the **only** definition [***10**] [****10**] for 'coupled' . . . includes a link, while ignoring the first definition . . . **from the same dictionary** which does **not** refer to a link," (*id.* (emphases in original)).

The Court agrees with Defendant.⁷ Indeed, the principle of claim differentiation requires that the Court accept Defendant's construction over Plaintiff's. "[C]laim differentiation takes on relevance in the context of a claim construction that would render additional, or different, language in another independent claim superfluous[.]" *Curtiss-Wright Flow Control Corp. v. Velan, Inc.*, **438 F.3d 1374** , **1381** (Fed. Cir. 2006). "[I]n the absence of any evidence to the contrary, we must presume that the use of . . . different terms in the claims connotes different meanings." *Applied Med. Res. Corp. v. U.S. Surgical Corp.*, **448 F.3d 1324** , **1333 n. 3** (Fed. Cir. 2006) (second alteration in original) (quoting *CAE Screenplates, Inc. v. Heinrich Fiedler GmbH & Co. KG*, **224 F.3d 1308** , **1317** (Fed. Cir. 2000)). Similarly, the construction of patent claim terms typically requires "meaning to be given to each part so as to avoid rendering any part superfluous." *Frans Nooren Afdichtingssystemen B.V. v. Stopaq Amcorr, Inc.*, **744 F.3d 715** , **722** , (Fed. Cir. 2014); see also *Info-Hold, Inc. v. Muzak LLC*, **783 F.3d 1365** , **1373** (Fed. Cir. 2015) ("Claims must be interpreted with an eye toward giving effect to all terms in the claim." (quotation omitted)). If, as Plaintiff posits, "coupled" "is not restricted to a direct coupling," (Pl.'s Infringement Reply Br., Dkt. 91 at 6), then the word "operably" as used in the phrase "operably coupled" in claim 11 would be rendered superfluous because the word "operably" would not have any additional meaning. Indeed, adopting Plaintiff's construction of "coupled" would not "giv[e] effect to all terms in the claim." *Info-Hold*, **783 F.3d at 1373** . To ensure that all claim terms do have meaning, then, the Court construes the term "coupled," standing alone, to mean "directly attached," whereas the broader term, "operably coupled," could also include indirect couplings.

The cases that Plaintiff cites for the proposition that "coupled" as allowing an indirect attachment are inapposite, and do not support Plaintiff's construction. (See Pl.'s Infringement Reply Br., Dkt. 91 at 6.) In those cases, the courts relied either on the principle of claim differentiation, construing the term "coupled" (or "coupled to") in light of the language in the patents at issue in those cases or relied on qualities specific to the arts at issue in those patents. See, e.g., *Bradford Co. v. Conteyor N. Am., Inc.*, **603 F.3d 1262**, 1270-71 (Fed. Cir. 2010) (holding that claim differentiation required an expansive reading of the term "coupled to" based on the language of the patent at issue); *Allen Med. Sys. Inc. v. Schuerch Corp.*, No 15-CV-13024 (GAO), [**2020 BL 239454**], 2020 U.S. Dist. LEXIS 112970, 2020 WL 3489611, at *3 (D. Mass. June 26, 2020) (similar); *Mizuho Orthopedic Sys., Inc. v. Allen Med. Sys.*, **610 F. Supp. 3d 367**, **373** (D. Mass. 2022) (looking to case law "concerning mechanical systems," which were at issue in that patent). Notably, in a case not cited by either party, the Federal Circuit held that "coupled" must be narrowly construed where a broad reading of the term would render claim language superfluous. See *In re Power Integrations, Inc.*, **884 F.3d 1370**, **1376-77** (Fed. Cir. 2018). The same logic plainly applies here.

The Court is equally unconvinced by Plaintiffs cited dictionary definition. While courts may rely **[*11] [**11]** on dictionaries to assist in properly construing claim terms, *Vitronics*, **90 F.3d at 1583**, the Federal Circuit has cautioned against relying on dictionary definitions at the expense of a considering "the meaning of the claim terms within the context of the patent," *Phillips*, **415 F.3d at 1321**. After all, "[d]ictionaries, by their nature, provide an expansive array of definitions. General dictionaries, in particular, strive to collect

all uses of particular words, from the common to the obscure. By design, general dictionaries collect the definitions of a term . . . in many different settings." *Id.* "Indiscriminate reliance on definitions found in dictionaries can often produce absurd results." *Renishaw PLC v. Marposs Societa' Per Azioni*, **158 F.3d 1243**, **1250** (Fed. Cir. 1998) (citation omitted). Instead, "the context" provided by the patent itself "will more often than not lead to the correct conclusion." *Id.* (citation omitted).

That is just the case here. In this instance, the Patent itself counsels toward a narrow definition of the term "coupled," as explained above. Where the Patent itself "lead[s] to the correct conclusion," there is no need to look at extrinsic evidence such as dictionary definitions. *Id.* In addition, as Defendant notes, Plaintiff here points to the *second* of two definitions provided in a single dictionary, and then erroneously asserts that this is the *only* definition provided in that dictionary and *must* therefore be the correct one, without acknowledging the first definition or explaining why the second, as opposed to the first, definition is the correct one. (See Pl.'s Infringement Reply Br., Dkt. 91 at 6; Coupled, Vocabulary.com, Dkt. 91-2 at ECF 3-4.) This is not persuasive—indeed, it is misleading, at best—and does not change the Court's mind about the proper construction of "coupled."

II. Patent Validity

Defendant moves for summary judgment on invalidity, arguing that the Patent is invalid due to obviousness. (See *generally* Def.'s Invalidity Br., Dkt. 97-1.) Plaintiff cross-moves for validity of the Patent. (See *generally* Pl.'s Validity Br., Dkt. 98.) For the reasons described below, the Court grants Plaintiff's motion and finds, as a matter of

law, that the Patent is valid.

A. Legal Standard for Obviousness

Patents are "presumed valid." **35 U.S.C. § 282(a)**. This presumption extends to "[e]ach claim of patent (whether in independent, dependent, or multiple dependent form)[.]" *Id.* This presumption can only be overcome through clear and convincing evidence. *SRAM Corp. v. AD-II Eng g*, **465 F.3d 1351**, **1357** (Fed. Cir. 2006). "The burden of establishing invalidity of a patent or any claim thereof" lies with "the party asserting invalidity." **35 U.S.C. § 282(a)**. This is a "heavy burden," and requires the party seeking invalidity to show by clear and convincing evidence "that the patent's invalidity is highly probable." *Speedfit LLC v. Woodway USA, Inc.*, **432 F. Supp. 3d 183**, **202** (E.D.N.Y. 2020) (citing *Active Video Networks, Inc.*, **694 F.3d at 1327**).

"A claimed invention is unpatentable if the differences between it and the prior art are such that the subject matter as a whole would have been obvious at the time the invention was made to a person having ordinary skill in the pertinent art." *In re Kahn*, **441 F.3d 977**, **985** (Fed. Cir. 2006) (citing **35 U.S.C. § 103(a)**). Whether an invention was "obvious is a [*12] [**12] legal conclusion based on underlying findings of fact." *Id.* The relevant factual determinations include "the scope and content of the prior art, differences between the prior art and the claims at issue, the level of ordinary skill in the pertinent art, and any objective indicia of non-obviousness." *Intercontinental Great Brands LLC v. Kellogg N. Am. Co.*, **869 F.3d 1336**, **1343** (Fed. Cir. 2017) (quoting *Randall Mfg. v. Rea*, **733 F.3d 1355**, **1362** (Fed. Cir. 2013)). In

considering these factual questions, "the district court can and should take into account expert testimony, which may resolve or keep open certain questions of fact." *Id.* at 1344 (quoting *KSR Int'l Co. v. Teleflex Inc.*, **550 U.S. 398**, **427**, **127 S. Ct. 1727**, **167 L. Ed. 2d 705** (2007)); *see also Enzo Biochem, Inc. v. Gen-Probe, Inc.*, **424 F.3d 1276**, **1284** (Fed. Cir. 2005) ("Attorney argument is no substitute for evidence."). After the fact issues are resolved, "[t]he ultimate judgment of obviousness is a legal determination' for the [C]ourt." *Intercontinental Great Brands LLC*, **869 F.3d at 1344** (quoting *KSR*, **550 U.S. at 427**). In reaching an obviousness determination, courts can also take into account "secondary considerations," which may have relevance as "indicia of obviousness or nonobviousness." *Graham v. John Deere Co. of Kansas City*, **383 U.S. 1**, **17-18**, **86 S. Ct. 684**, **15 L. Ed. 2d 545** (1966). Secondary considerations may include "commercial success, long felt but unsolved needs, [and the] failure of others" to solve the issue that the patent seeks to address. *Id.* at 17.

Though questions of fact are present in this analysis, "[d]epending on the record, summary judgment of invalidity for obviousness may be appropriate." *Intercontinental Great Brands LLC*, **869 F.3d at 1344**. Where "the content of the prior art, the scope of the patent claim, and the level of ordinary skill in the art are not in material dispute, and the obviousness of the claim is apparent . . . , summary judgment is appropriate." *Id.* (quoting *KSR*, **550 U.S. at 427**).

B. Analysis

In its motion for summary judgment on invalidity, Defendant argues that the Patent is invalid due to obviousness based on "a combination of one

or more primary references, Carey, Adams, and the Black Brand ('Axe') vest, in view of one further reference, Fitch." (Def.'s Invalidity Br., Dkt. 97-1 at 6, 17-24.) In particular, Defendant argues that the only difference between the prior art, on the one hand, and the Patent, on the other, is the placement of the zipper. (*Id.* at 24.) Defendant further argues that the placement of a zipper is merely a nonfunctional design choice that "a person of **ordinary** skill" could have made. (*Id.* (emphasis in original).)

In addition to responding to Defendant's motion, Plaintiff cross-moves for summary judgment on validity of the Patent. (Pl.'s Validity Br., Dkt. 98 at 1.) In its brief, Plaintiff does not dispute that the Carey, Adams, and Fitch patents, as well as the Black Brand Axe vest, are relevant prior art under **35 U.S.C. § 102**. (*Id.* at 16 n.4.) Instead, Plaintiff argues that even in light of these references, the Patent is nonobvious, and therefore is valid. (*See generally id.*)

1. Person of Ordinary Skill in the Art

Neither party in this action accurately presents the respective experts' opinions as to who is a "person of ordinary skill in the art" ("POSA") for purposes of determining the Patent's validity: although Plaintiff's expert, Robin Wagner, applied defense expert Dorbiana **[*13]** **[**13]** Gheneva's definition of a POSA,⁸ Wagner disagreed with that definition. (*See* Robin Wagner Dep. ("Wagner Dep."), Dkt. 97-25 at 46:21-47:5 (Wagner testifying that she believed Gheneva's POSA definition was incorrect, but that she would use it anyway).) Plaintiffs response brief suffers from a similar defect: Plaintiff states that its own expert "Wagner

actually testified that Ms. Gheneva's . . . definition is more appropriate." (Pl.'s Validity Br., Dkt. 98 at 15.) Not so. Wagner testified that she applied Gheneva's definition even though she disagreed with it, seemingly for the sake of argument. (Wagner Dep., Dkt. 97-25 at 46:21-47:5.) Thus, the parties' experts clearly disputed (and presumably still dispute) the proper definition of POSA in this matter. Furthermore, neither party knows what Gheneva's POSA definition actually is or they disagree about what it is. Defendant represents that their expert Gheneva's POSA definition is "a person having 1-2 years of formal education in design, technical design or pattern making and 1-3 years of working experience in the field." (Def.'s Invalidity Br., Dkt. 97-1 at 19.) Meanwhile, Plaintiff says that Defendant mischaracterizes their own expert's POSA definition, which Plaintiff describes, in comparison to the above-quoted definition, as "more education with less work experience, or less education with more work experience." (Pl.'s Validity Br., Dkt. 98 at 15.)⁹ But, in fact, both sides appear to misstate Gheneva's POSA definition, at least based on the sworn declaration Gheneva submitted in connection with the claim construction proceedings in this case, in which Gheneva states that the relevant POSA is someone with "2-4 years of formal education in design, technical design or pattern making and 1-3 years of working experience in the field." (Gheneva Decl., Dkt. 54-1 ¶ 12.)

The Court is now faced with three different POSA definitions and virtually no relevant argument apart from the parties' statements that both sides applied Gheneva's POSA definition. The Court therefore finds that, as a matter of law, both parties have waived any material dispute on this issue. *See In re Gabapentin Patent Litig.*,

503 F.3d 1254 , **1261-62** (Fed. Cir. 2007) (finding argument waived when it was not raised on summary judgment). In light of that, the Court adopts the POSA definition provided by Gheneva herself¹⁰ in her declaration: a POSA is someone with "2-4 years of formal education in design, technical design or pattern making and 1-3 years of working experience in the field." (Gheneva Decl., Dkt. 54-1 ¶ 12.)

2. Obviousness

Because there are no questions of material fact as to any of the underlying factual considerations—i.e., the content of prior art, the scope of the patent, and the POSA definition—the Court can make a determination as to obviousness. *Intercontinental Great Brands LLC*, **869 F.3d at 1344** . The Court analyzes the cross-motions for summary judgment on validity separately. *Morales*, **249 F.3d at 121** ("[E]ach party's motion must be examined on its own merits, and in each case all reasonable inferences must be drawn against the party whose motion is under consideration.").

a. Defendant's Motion for Summary Judgment of Invalidation

In support **[*14]** **[**14]** of its motion for summary judgment on invalidity, Defendant argues that Plaintiffs expert—that is, Wagner—"has agreed that the only difference between the [prior art in question] and the claimed invention is the placement of the zipper (fastener)" and that this is a "trivial" design difference. (Def.'s Invalidation Br., Dkt. 97-1 at 22 (citing Def.'s R. 56.1 on Invalidation, Dkt. 97-5 ¶ 135, in turn quoting Wagner Dep., Dkt. 97-25 at 110:9-12, 132:14-

17).) This mischaracterizes Wagner's testimony. While it is true that Wagner testified that the only difference between the Patent and the prior art is the placement of the zipper, (see Wagner Dep., Dkt. 97-25 at 110:9-12, 132:14-17), she did not testify that zipper placement was merely a design difference. To the contrary, she testified that zipper placement was *not* a design choice, but instead was a "functional" choice. (*Id.* at 110:13-111:7 (explaining, *inter alia*, that 'design choice' is something that does not affect the function of a garment"), 132:18-21.) Additionally, Defendant has not provided any evidence—for example, its own expert testimony or report—that would contradict Wagner's testimony that the placement of the zipper was a nonobvious functional choice. (See *generally* Def.'s Invalidation Br., Dkt. 97-1; Def.'s R. 56.1 on Invalidation, Dkt. 97-5.) As a result, it has not carried its burden to produce clear and convincing evidence that the Patent was obvious, nor demonstrated a genuine dispute of material fact on this issue. Defendant's motion for summary judgment of invalidity is therefore denied.

b. Plaintiffs Cross-Motion for Summary Judgment of Validity

By contrast, Plaintiff has demonstrated as a matter of law that the Patent is valid. The Court agrees with Plaintiff that the Patent was not obvious based on prior art largely for the reasons set forth in Plaintiffs brief. (See Pl.'s Validity Br., Dkt. 98.) As Plaintiff explains, each prior art reference is readily distinguishable from the Patent. (*Id.* at 16-23.) Specifically, the Carey and Adams patents do not provide for a fastener, e.g., a zipper, that would provide access to the back outer layer of the garment at all. (Canadian Patent App. No. 2,244,701, Dkt. 97-13; AU

Patent App. No. 2013100214 A4, Dkt. 97-14.) The zipper placements of both the Carey and Adams patents only provide access to the front panels of the outer garment. (*Id.*) The Black Brand Axe vest and the Fitch patent arguably do have fasteners that provide access to the back outer layer, however, they do not provide for an opening on or near the first perimeter, which is a key element of the each of the Patent claims. ([U.S. Patent No. 2](#), 594 ,259, Dkt. 97-15; Def.'s R. 56.1 on Invalidity, Dkt. 97-5 ¶ 100.) Instead, the Black Brand Axe vest has a U-shaped zipper that allows a portion of the vest's liner to open outward, (Def.'s R. 56.1 on Invalidity, Dkt. 97-5 ¶ 100), and the Fitch patent provides for a zipper that fully encircles the inner lining, which can disconnect from the outer layer of the garment and serve as a separate garment, ([U.S. Patent No. 2](#), 594 ,259, Dkt. 97-15). Defendant's conclusory argument that a combination of these references renders the Patent obvious because a "zipper could be placed anywhere," (Def.'s Invalidity Br., Dkt. 97-1 [*15] [**15] at 24), is an unsupported oversimplification.

The secondary considerations that Plaintiff raises also support a finding of validity. As Maqbool, Plaintiff's Chief Executive Officer and creator of the invention protected by the Patent, testified, the inability to easily attach patches to the back of leather jackets and vests has been a longstanding problem—one that he sought to solve through the Patent. (Maqbool Dep., Dkt. 98-3 at 105:5-106:25.) Indeed, as a Tucker Rocky representative testified, Tucker Rocky attempted to solve the very same problem with its U-shaped zipper compartment on its Black Brand vests. (Kelly Dep., Dkt. 97-16 at 14:1-13, 20:7-13.) But the Black Brand vests' meager sales—and resultant short-lifespan—indicates that Tucker Rocky was not entirely successful in

solving this problem. (Whitney Dep., Dkt. 97-17 at 35:18-36:6.) The comparatively greater sales of Plaintiff's Milwaukee Leather products, which utilize the invention protected by the Patent, suggest that Maqbool's invention was in fact a nonobvious improvement over what had come before, as opposed to merely an aesthetic design choice. (Wagner Dep., Dkt. 97-25 at 144:4-20.) For these reasons, the Court finds the Patent to be valid.

III. Infringement

The parties also cross-move for summary judgment on the issue of infringement. (*See generally* Pl.'s Mem. Supp. Summ. J. on Infringement, Dkt. 88-2; Def.'s Infringement Resp. Br., Dkt. 89 at 1.) For the reasons explained below, Defendant's motion for summary judgment on noninfringement is granted as to claims 1 through 10. Defendant's motion for summary judgment on noninfringement, and Plaintiffs motion for summary judgment on infringement, are both denied as to claims 11 through 18. Those claims will thus proceed to trial.

A. Legal Standard

"A two-step process is used in the analysis of patent infringement: first, the scope of the claims are determined as a matter of law, and second, the properly construed claims are compared to the allegedly infringing device to determine, as a matter of fact, whether all of the limitations of at least one claim are present, either literally or by a substantial equivalent, in the accused device." *Teleflex, Inc. v. Ficosa N. Am. Corp.*, [299 F.3d 1313](#), [1323](#) (Fed. Cir. 2002); *see also Nassau Precision Casting Co., Inc. v. Acushnet Co., Inc.*,

95 F. Supp. 3d 332 , **347** (E.D.N.Y. 2015). "Summary judgment is appropriate" in this context "when it is apparent that only one conclusion as to infringement could be reached by a reasonable jury." *TechSearch, L.L.C. v. Intel Corp.*, **286 F.3d 1360** , **1369** (Fed. Cir. 2002) (citing *ATD Corp. v. Lydall, Inc.*, **159 F.3d 534** , **540** (Fed. Cir. 1998)).

B. Analysis

There is a question of material fact as to whether the Accused Products infringe on Patent claims 11 through 18, but not as to claims 1 through 10. In its motion, Plaintiff alleges literal infringement only (as opposed to infringement by substantial equivalents). (See Pl.'s Mem. Supp. Summ. J. on Infringement, Dkt. 88-2 at 17-23.) Defendant, on the other hand, alleges three key differences between the Accused Products and the Patent in arguing that the Accused Products do not infringe: (1) that the opening on the Accused Products is not on the first perimeter; (2) that there is no uncoupled [*16] [**16] portion of the liner and outer layer at the first perimeter; and (3) that the zipper for the opening is not attached to both the liner and the outer layer of the garment. ¹¹ (Def.'s Infringement Resp. Br., Dkt. 89 at 12-17.)

First, Defendant argues that the opening to access the back panel of the garment on the Accused Products (i.e., the zipper) is not located on the first perimeter as required by the claims, and so the Accused Products necessarily do not infringe on the Patent. (*Id.* at 12.) Each of the Patent's independent claims requires that the garment's liner have a "first perimeter being a substantially outermost extent of the back portion" of the garment where an "opening" or "space . . . accessible through the opening" is

formed. (Patent, col. 4 11. 61-62, *id.* col. 5 11. 43-44, *id.* col. 6 11. 1-2, 27-28, Dkt. 88-5 at ECF 10-11.) If it is true that the opening is not found on the "[f]irst [p]erimeter," which is located at the "substantially outermost extent of the back portion" of the Accused Products, then Defendant is correct that their products do not infringe. (Def.'s Infringement Resp. Br., Dkt. 89 at 12.)

To determine the veracity of this contention, it is necessary to closely examine the meaning of "outermost extent" in the Patent. Substituting the words "back portion" and "substantially outermost extent" with their meanings as previously construed by this Court, the "first perimeter" is defined as "being *at or near* the boundaries of the portion of the outer layer that covers the entire back panel of the garment." (Patent, col. 4 11. 61-62, Dkt. 88-5 at ECF 10 (emphasis added); Claim Construction M&O, Dkt. 71 at 26); *see also Shaf Int'l, Inc.*, *2022 U.S. Dist. LEXIS 125700* , *2022 WL 2791999* . Because the "first perimeter" includes not only the outermost boundaries of the garment, but also the areas *near* the boundaries of the garment, a reasonable jury could find for either party on this issue. It is clear from the Accused Product images that the opening on the Accused Products is not *on* the boundary of the back portion of the garment. (See Exh. 3 to Espinal Decl., Dkt. 89-4.) However, a jury could find that the opening is *near* the boundary of the back portion of the garment. Consequently, this argument does not conclusively show noninfringement. Instead, it demonstrates that there is a question of material fact as to infringement.

Next, Defendant argues that the liner and outer layer at the first perimeter of the Accused

Products are "completely and permanently attached" because the liner on the Accused Products is directly connected to the outer layer of the jacket by a seam that runs along the jacket's entire bottom edge. (Def.'s Infringement Resp. Br., Dkt. 89 at 15.) The zipper that creates the opening to access the outer layer of the garment on the Accused Products is attached only to the liner, unlike the products protected by the Patent, where the zipper is directly connected both to the liner and the outer layer of the garment. (*See id.*; *see also* Exh. 3 to Espinal Decl., Dkt. 89-4.) As with Defendant's first argument on infringement, this argument rests on the "first perimeter" being defined as the garment's "outermost boundaries" only, and not *near* the outermost boundaries of the garment. [*17] [**17] (Def.'s Infringement Resp. Br., Dkt. 89 at 15.) But the Court has construed "outermost extent" as meaning "at *or near* the boundaries," not as meaning "on the boundaries." (*See* Claim Construction M&O, Dkt. 71 at 26); *see also* *Shaf Int'l, Inc., 2022 U.S. Dist. LEXIS 125700*, *2022 WL 2791999*. So, for the same reasons as explained above, there is a question of material fact as to whether the Accused Products have an "uncoupled portion" at the first perimeter. (*Id.*) A reasonable jury could find that the "liner is not coupled to the outer layer when the zipper is opened" and that that "uncoupled portion" is near the outermost boundaries of the back panel of the Accused Products. (Pl.'s Infringement Reply Br., Dkt. 91 at 5; Exh. 16 to Maqbool Decl., Dkt 88-3 at ECF 20 (demonstrating space created between liner and outer layer of jacket when zipper is unzipped).) This would mean that the Accused Products *do* infringe. At the same time, a jury could reach the opposite finding. Thus, there is a question of material fact as to whether the Accused Products meet this claim requirement.

Third, Defendant argues that the zipper for the opening is not attached to both the liner and the outer layer of the garment as required in independent claim 1, as well as claims 2 through 10 which depend thereon. (Def.'s Infringement Resp. Br., Dkt. 89 at 16-17.) Claim 1 requires that the garment have "a fastener, having a first member coupled to said inner surface and a second member coupled to said liner at an uncoupled portion of said first perimeter[.]" (Patent, cols. 4-5 11. 66-1, Dkt. 88-5 at ECF 10-11.) But as Jorge Espinal, Defendant's general manager, explains in his declaration, "[a]t no point . . . in any [] Accused Product is the zipper coupled, or [directly] attached to the outer layer. The zipper is always attached to the liner on both the top and the bottom." (Espinal Decl., Dkt. 89-1 ¶¶ 1, 21.) The submitted photos of one of the Accused Products underscores Espinal's assertion. (*See* Photo of High Roller Vest, Dkt. 89-4.) And given the Court's construction of the term "coupled" as meaning "directly connected," no reasonable jury could find that the Accused Products contain a fastener that is coupled to the outer layer. (*See id.*; Espinal Decl., Dkt. 89-1 ¶ 21.) As a result, Defendant's motion for summary judgment of noninfringement is granted as to claims 1 through 10.

Because an accused product need only meet all of the limitations of one claim to infringe on a patent, *Teleflex, Inc.*, **299 F.3d at 1323**, a jury could still find that the Accused Products infringe on the Patent with respect to claims 11 through 18. Defendant's motion for summary judgment of noninfringement and Plaintiff's motion for summary judgment on infringement as to those claims, then, are both denied. But Defendant's motion for summary judgment of noninfringement is granted as to claims 1 through 10.

CONCLUSION

For the foregoing reasons, the Court construes the term "coupled" as meaning "directly attached." In addition, the Court denies Defendant's motion for summary judgment on invalidity and grants Plaintiffs cross-motion for summary judgment on this issue and finds that the Patent is valid as a matter of law. The Court finds that the Accused Products do not infringe [*18] [**18] Patent claims 1 through 10 as a matter of law, and as a result, the Court grants Defendant's motion for summary judgment of noninfringement as to those claims. Both parties' cross-motions for summary judgment on infringement are denied as to claims 11 through 18. Plaintiffs infringement cause of action will proceed as to those Patent claims. Finally, because neither party has moved for summary judgment on the false marking claim, that claim will also proceed to trial.

SO ORDERED.

/s/ Pamela K. Chen

Pamela K. Chen

United States District Judge

Dated: September 26, 2024

Brooklyn, New York

fn

1

Before issuing the Patent, the PTO received a provisional patent application from Plaintiff on January 19, 2017, and a nonprovisional patent application claiming priority to the

provisional application filed by Plaintiff on July 6, 2017. (Patent, Dkt. 88-5 at ECF 1.) The nonprovisional application was published on October 26, 2017. (*Id.*)

fn

2

Citations to "ECF" refer to the pagination generated by the Court's CM/ECF docketing system and not the document's internal pagination.

fn

3

Unless otherwise noted, a standalone citation to a party's 56.1 statement denotes that this Court has deemed the underlying factual allegation undisputed. Any citation to a 56.1 statement incorporates by reference the documents cited therein.

fn

4

On August 5, 2020, nearly five months after Plaintiff commenced this action, Defendant filed a petition to revive the '014 Application. (See Decl. of Peter I. Bernstein & attached USPTO Patent Docket for Patent Application #15/599,014, Dkt. 25 at ECF 1-2.)

fn

5

The opening is on the inside of the jacket, but it allows access to the inside of the jacket's outer layer to attach the badge onto the outside of the outer jacket.

fn

6

The Patent also includes 15 dependent claims. For brevity's sake, the Court only includes the independent claims here.

Notably, neither party provides Wagner's or Gheneva's expert reports. Instead, only Wagner's deposition testimony is provided, which obliquely refers to the opinions in the expert reports. (*See, e.g.,* Wagner Dep., Dkt. 97-25 at 46:11-47:5.)

fn

7

Where, as here, the Court is able to properly construe the term at issue without expert testimony, a *Markman* hearing is not necessary. *Mich & Mich. TGR, Inc. v. Brazabra, Corp.*, **128 F. Supp. 3d 621**, **635** (E.D.N.Y. 2015) (explaining that a *Markman* hearing is not necessary when the disputed claim term is neither ambiguous nor highly technical); *see also Revlon Consumer Prods. Corp., 2003 U.S. Dist. LEXIS 13004*, *2003 WL 21751833*, at *14 (collecting cases) (same).

fn

10

Because Gheneva's declaration was provided as part of the earlier claim construction briefing, the Court recognizes that it is possible that Gheneva's POSA definition changed between the time she submitted that declaration and the time of her expert report and/or her deposition. However, because her expert report and deposition are not currently before the Court, the Court cannot rely on them.

fn

8

Although not expressly stated in Wagner's deposition, the implication is that Wagner applied Gheneva's POSA definition for the sake of argument to illustrate that even using the defense's POSA definition, the Patent was still not obvious.

fn

11

The third contention is relevant only to claims 1 through 10, while the first two contentions are relevant to all claims. (Def.'s Infringement Resp. Br., Dkt. 89 at 16.) Plaintiff, however, does not assert claims 8 and 9, so the third contention is relevant only to claims 1 through 7 and 10. (*See* Pl.'s Infringement Reply Br., Dkt. 91 at 5 n.3.)

fn

9

General Information

Case Name	Shaf Int'l, Inc. v. First Mfg. Co.
Court	U.S. District Court for the Eastern District of New York
Date Filed	Thu Sep 26 00:00:00 EDT 2024
Judge(s)	Pamela Ki Mai Chen
Parties	SHAF INTERNATIONAL, INC., Plaintiff, - against - FIRST MANUFACTURING CO., INC., Defendant.
Topic(s)	Civil Procedure; Copyright Law; Trademark Law; Patent Law